



THE LITTLE

December 2017/January 2018 - Vol. 32, Issue 6

MOWA

onsite wastewater association

DIGGER

A bi-monthly publication

Upcoming 2018 MOWA Convention is “get-away” with CEUs Enjoy all the amenities at Arrowwood Resort and Conference Center



The 2018 MOWA Convention promises to be a great get-away for members! Arrowwood Resort & Conference Center has 28,000 sq. ft. of flexible meeting space, a scenic lake setting, beautifully appointed overnight accommodations, and well-equipped meeting rooms. Combine those offerings with the 14,400 sq. ft. Exhibit/Recreation Center connected directly to the Convention Center and you've got the winning formula for a relaxed learning experience!

Convention Preview—

Alexandria Community & Technical College staff to present on changes to MN truck weight laws

Each year, truck traffic is increasing in Minnesota. Recent legislation has changed some longstanding truck-weight laws. Additional gross weights are possible for several commodities provided the trucks are configured correctly and the additional weight is authorized by the governing road authority. The 2017 Minnesota legislature made changes to increase weights in the dairy industry; effective in 2018, legislative changes will allow additional weight for the transportation of construction materials.

The Minnesota Truck-Weight Education Program addresses issues and concerns from state, county, city, and township transportation authorities regarding truck weight. Information is provided that explains road weight regulations during

various times of the year, including the winter load increase and spring load restrictions. The program promotes voluntary compliance to reduce damage to public roads and highways from overweight vehicles. The program goal is to

Preview: Truck Weight Regs, Continued on Page 14

In this Little Digger

Convention Preview: Truck Weight...	Pg. 1
Executive Director's Column	Pg. 3
2018 Convention Overview	Pg. 4
2018 Attendee Registration	Pg. 5
2018 Convention Schedule/Sign-Up .	Pg. 6
Calendar of Events	Pg. 6
2018 Convention Exhibitor Sign-Up .	Pg. 7
2018 Convention Photo Contest.....	Pg. 8
NOWRA 2018 Mega-Conference Info...Pg.	8
Consumer Alert: Freezing Septics .	Pg. 9
MPCA: 2017 SSTS Report Info	Pg. 10
MPCA: SSTS Committee Op.....	Pg. 10
MPCA: Rulemaking & Annual Rpt. ..Pg.	11
MPCA: Rule Amendment & Tour	Pg. 12
MPCA: 3rd Q. Enforcement Info	Pg. 12
MPCA: Consumer Ed Magnet	Pg. 14
Convention Highlight: Septics/CECs	Pg. 15
2018 OSTP Course Listing	Pg. 16
2018 OSTP Registration Form	Pg. 18
2018 MOWA Membership Form	Pg. 19



REACHING FURTHER

ALL DAY. EVERY DAY.

DO MORE WITH THE CAT® F SERIES

The next generation of Cat hydraulic excavators is designed to reach further — to set new industry standards for productivity — all day, every day.

- Greater lift capacity and digging force result in higher productivity
- Cab improvements increase operator comfort
- Multiple Cat Work Tools available for a wide range of applications
- Cat Grade Control allows real-time bucket tip elevation guidance

MINNESOTA 800.352.2812

Bemidji • Brainerd • Buhl • Columbus • Crookston • Duluth • Fergus Falls • Jackson
Mankato • Marshall • Minneapolis • Rochester • Shakopee • St. Cloud • Willmar

ZIEGLER 

www.zieglercat.com



From MOWA's Executive Director

By Pat Martyn, MOWA Executive Director

2018 Annual MOWA Convention Arrowwood Resort, Alexandria January 30 - 31, 2018

We are happy to announce it is Convention Time! Our Annual Convention and the great Minnesota Septic Get-Together is coming up on January 30th & 31st, 2018. The site is the Arrowwood Resort in Alexandria – always a favorite with our group. It is big, beautiful, and will accommodate two great days of information, education, fun, and friendship.

This year, back by popular demand, we are offering a two-day format, but rest assured you can still get your CEUs, along with the same networking opportunities and fun events that our Convention Committee has put together. We will once again be holding a Roe-d-Hoe® competition, with the 1st prize winner going to compete at the Fall 2018 National Convention in Minneapolis. Plus, it's time again for MOWA's Wastewater Olympics on Tuesday evening following the auction: It's FREE, FUN, and there are hundreds of dollars in prizes! Sign-up during the day on Tuesday.

You can find right here in the Little Digger information about the show, and you can tell we are really excited about the prospect of a great event. And, there is a handy registration that you can use to attend the show. There are other ways of registering as well, so choose the one that works best for you. Even if you have to call the office directly, we will get it done.

Attendees year after year cite the benefits of attending. We repeatedly get very high marks for the content of the show. Your opportunity to mingle with friends and colleagues in the industry and hash out items of interest, catch up on news or just some friendly conversation is a real benefit of the show.

Exhibits hosted by the sponsors present the best products available. Reputable vendors will be at the show to display their wares, describe them to you, sell you if you are interested, and generally, inform and explain. If you are interested in becoming an exhibitor, registration information is available in these pages as well.

Everyone should take advantage of the fact that we are privileged to have decision makers from the Minnesota Pollution Control Agency attend the show. This makes an opportunity to visit with our State regulatory authority, and gain valuable insights into their enforcement responsibility, or ask a question that has been puzzling to you. In addition, the MPCA will present on timely topics, and will be doing their usual great job of informing the industry.

Lastly, do you want to play a more involved role in Board decision making process? Let us know if you are interested in running for a spot on the Board. Elections are held at the Convention, and we are looking for a few good people to fill the posts of departing Board Members.

How important is the Onsite Industry's work to protect water quality?

"Communities in Greater Minnesota face special challenges to ensure that their citizens have access to clean water for drinking, washing, agriculture, business, and recreation... These challenges are everyone's responsibility, and everyone's opportunity."

Governor Mark Dayton, 2017 Water Summit, University of Minnesota-Morris

[To register for the Convention offering on Pharmaceuticals
and Personal Care Products, go to Page 6](#)

MOWA

2017 BOARD OF DIRECTORS

Dean Flygare, President
Flygare Excavating, Inc.
deanflygare@gmail.com
320-980-3856

Andy Winkler, President-Elect
Wieser Concrete
winkler@wieserconcrete.com
715-647-2311

Shane Steinbrecher, Past-President
Steinbrecher Companies
shane@steinbrechercompanies.com
612-221-8675

Cindy Tiemann, Secretary
Fiedler's Your Pumping
Specialists
cindy@fiedlerpumping.com
320-252-9916

Pete Otterness, Treasurer
Nicollet County
pete.otterness@co.nicollet.mn.us
507-934-7076

Eric Blasing
Wenck Associates
eblasing@wenck.com
651-428-8038

Mike Capra
Capra's Utilities
mike@capras.com
651-762-2500

Stacey Feser
Feser Environmental
staceyfeser@gmail.com
612.382.7491

Nick Haig
MPCA
nick.haig@state.mn.us
651-757-2536

Chris LeClair
Washington County
chris.leclair@co.washington.mn.us
651-430-4052

Bernie Miller
Miller's Sewage Treatment
Solutions
bernie@millerssewage.com
320-398-2705



2018 Minnesota Onsite Wastewater Convention
"Working Together to Protect Water"
Arrowwood Resort – Alexandria, MN
January 30th & 31st, 2018

Convention Overview

Tuesday, January 30th:

◆ Trade Show Set-Up	7:00 am - 11:00 am
◆ Registration	7:30 am - 9:00 am
◆ MOWA President's Welcome	8:00 am - 8:15 am
◆ NOWRA Update	8:15 am - 8:45 am
◆ MPCA Update	8:45 am - 9:35 am
◆ Keynote Speaker: William B. DeOreo	9:35 am - 10:25 am
◆ Keynote Speaker: Tannie Eshenaur	10:25 am - 11:15 am
◆ Trade Show Opens – Roe-d-Hoe®	11:15 am - 12:00 pm
◆ Lunch with Vendor Introductions / Annual Meeting / Open Forum	12:00 pm - 1:15 pm
◆ MPCA Retest*	1:00 pm - 5:00 pm
◆ Vendor Show – Appetizers & Cash Bar / Games, Prizes!	3:00 pm - 6:00 pm
◆ Wastewater Olympics	6:00 pm - 8:00 pm

Wednesday, January 31st:

◆ Registration	7:30 am - 9:00 am
◆ Tracks 1 – 3	8:00 am - 12:30 pm
◆ Tank Manufacturers Meeting**	10:00 am - 10:50 am
◆ Lunch	12:30 pm - 1:30 pm
◆ Tracks 1 – 3	1:30 pm - 4:30 pm
◆ MOWA Board Meeting	4:30 pm - 5:00 pm
◆ Convention Close	5:00 pm

*MPCA Retest available at no fee

**Tank Manufacturers Meeting Attendees must register for at least one day of the convention to attend

Attendee Sponsorship Opportunities

- \$25 – Bronze Sponsor: Acknowledgement on Conference Signage
- \$50 – Silver Sponsor: Acknowledgement on Conference Signage and in Conference Packet
- \$100 – Gold Sponsor: Acknowledgement on Conference Signage and in Conference Packet, on MOWA Website and Facebook Page
- \$250 – Platinum Sponsor: Acknowledgement on Conference Signage and in Conference Packet, on MOWA Website and Facebook Page, plus link to your business website

Payment:

Check: Payable to MOWA **Amount:** \$ _____
Mail to: MOWA, 5021 Vernon Ave., So., #241, Edina, MN 55436

Credit Card: Fax to - (952) 487-4447, Mail to - address above, or Email to - mowacarla@aol.com

Type of Card: Visa MasterCard **Amount:** \$ _____

Credit Card # _____ Expire Date: _____ / _____ CVV Code: _____

Cardholder: _____ Signature: _____

By this signature I authorize MOWA to process fees pertaining to this MN Onsite Wastewater Convention.



2018 Minnesota Onsite Wastewater Convention
"Working Together to Protect Water"
Arrowwood Resort - Alexandria, MN
January 30th - 31st, 2018

Attendee Registration

Deadline: January 12th, 2018

Please print (One form per person, please make copies for additional individuals)

Company Name: _____ Contact: _____
Address: _____
City, State, Zip: _____
Phone: _____ Fax: _____ E-Mail: _____

MOWA Members

By January 12th, 2018:

- Both Days - 1st Company Rep. \$275
Both Days - Subsequent Rep. \$225
1 Day: Tues. OR Weds.- 1st Company Rep. \$175
1 Day: Tues. OR Weds.- Subsequent Rep. \$150

After January 12th, 2018: WALK-IN

- Both Days - 1st Company Rep. \$375
Both Days - Subsequent Rep. \$325
1 Day: Tues. OR Weds.- 1st Company Rep. \$275
1 Day: Tues. OR Weds.- Subsequent Rep. \$250

Registration includes Admission, Luncheons, Reception, Trade Show, Entertainment AND Education (Everyone receiving CEUs must pay) GREAT VALUE FOR YOUR EDUCATION DOLLARS!

Non-Members*

By January 12th, 2018

- Both Days - \$375
1 Day: Tues. OR Weds - \$275

After January 12th, 2018: WALK

- Both Days - \$475
1 Day: Tues. OR Weds - \$325

For our Business/Government members, 1st attendee registers at the "1st Company Rep." rate; all other attendees who are members of the same organization receive the "Subsequent Rep." rate.

*Join or renew your membership today and receive member conference rates (see back page of the Little Digger of the application)

Total Attendee Registration:

General Registration

Please circle the day(s) you will attend: Tuesday - Wednesday

= \$ _____

Additional Lunch and/or Trade Show Tickets (1 ticket for each event)

Lunch Name: _____ Name: _____ # _____ X \$35.00 = \$ _____

Trade Show Name: _____ Name: _____ # _____ X \$35.00 = \$ _____

Grand Total = \$ _____

Payment:

Check: Payable to MOWA

Mail to: MOWA, 5021 Vernon Ave., So., #241, Edina, MN 55436

Amount: \$ _____

Credit Card: Fax to (952) 487-4447, Mail to - address above, or Email to - mowacarla@aol.com

Type of Card: Visa MasterCard

Amount: \$ _____

Credit Card # _____ Expire Date: _____ / _____ CVV Code: _____

Cardholder: _____ Signature: _____

By this signature I authorize MOWA to process fees pertaining to this MN Onsite Wastewater Convention.

I agree to indemnify and hold harmless Minnesota Onsite Wastewater Association (MOWA), from any and all liability, loss, damage, or expense from any incident which may arise while attending any portion of the 2018 MOWA Annual Convention. If applies, I authorize any photos taken of me at this event to be published in MOWA's Little Digger and/or other MOWA -related promotional materials.

Signature: _____ Date: _____

Cancellation Fee: \$100. Written notice of cancellation must be received in the MOWA office no later than 01/22/18. No refunds after 01/22/18.

Attendee Name:					
MOWA 2018 Convention - Education Schedule & Sign-Up (please complete and return to the MOWA office with your Convention registration) Schedule subject to change; CEU's Subject to MPCA Approval					
TUESDAY, JANUARY 30, 2018					
Time		Topic/(CEU)		SELECTION	
8:45 AM	9:35 AM	MPCA SSTS Program Perspectives (1.00 D)		<input type="checkbox"/> I will attend	
9:35 AM	10:25 AM	Keynote: Trends in Residential Water Use (1.00 I)		<input type="checkbox"/> I will attend	
10:25 AM	11:15 AM	Keynote: Minnesota's Water Legacy (1.00 I)		<input type="checkbox"/> I will attend	
Time		Track I Design & Installation	Track II Performance & Monitoring	Track III Pumps & Controls	SELECTION
1:00 PM	5:00 PM	MPCA Retesting (offered at no charge) (0.00)			<input type="checkbox"/> I will attend
1:20 PM	2:10 PM	Open Forum: Design & Installation (1.00 D)	Pharmaceuticals & Personal Care Products - What You Need to Know (1.0 D)	Pump Selection & Sizing (1.0 D)	<input type="checkbox"/> T1 <input type="checkbox"/> T2 <input type="checkbox"/> T3
2:10 PM	3:00 PM	Open Forum: Design & Installation (1.00 D)	Whole System Monitoring (1.0 D)	Basic Electrical Theory and Troubleshooting as it Relates to Floats and Onsite Septic Controls (1.0 D)	<input type="checkbox"/> T1 <input type="checkbox"/> T2 <input type="checkbox"/> T3
WEDNESDAY, JANUARY 31, 2018					
Time		Track I Maintenance & Service Providing	Track II AM: Local Programs & Inspections PM: Mix	Track III Design & Install Topics	SELECTION
8:00 AM	8:50 AM	Overview of 503 Regulations with Land Application Examples (1.0 D)	Open Forum: Local Units of Government/Inspector (1.00 D)	Managing Hydrogen Sulfide Gas Concentrations in Wastewater Treatment Tanks (1.0 D)	<input type="checkbox"/> T1 <input type="checkbox"/> T2 <input type="checkbox"/> T3
8:50 AM	9:40 AM	Record and Land Application Review along with Q & A (1.0 D)	Open Forum: Local Units of Government/Inspector (1.00 D)	Design Drawing Options & Examples (1.0 D)	<input type="checkbox"/> T1 <input type="checkbox"/> T2 <input type="checkbox"/> T3
10:00 AM	10:50 AM	I Spilled, Now What? (1.0 D)	LGU Data Management (1.00 D)	MPCA Technical Update (1.00 D)	<input type="checkbox"/> T1 <input type="checkbox"/> T2 <input type="checkbox"/> T3
10:00 AM	10:50 AM	Tank Manufacturers Meeting (note: must register for at least one day of the convention to attend this meeting) (0.00)			<input type="checkbox"/> I will attend
10:50 AM	11:40 AM	Open Forum: Maintainer (1.00 D)	State and Local Program Administration (1.00 D)	Advanced Design Decision-Making (1.00 D)	<input type="checkbox"/> T1 <input type="checkbox"/> T2 <input type="checkbox"/> T3
11:40 AM	12:30 PM	Open Forum: Maintainer (1.00 D)	30 Marketing Ideas in 50 Minutes (0.00)	Other Establishment Concerns – Case Studies for Dental Clinics and Group Homes (1.00 D)	<input type="checkbox"/> T1 <input type="checkbox"/> T2 <input type="checkbox"/> T3
1:30 PM	2:20 PM	Case Study: How Does Use in the Home Impact the Need for Septic Tank Pumping (1.00 D)	The Internet, Social Media and Your Online Reputation – And Why It Matters (0.00)	IPS Weld-On 724 Solvent Cement for Joining PVC or CPVC Chemical Piping (1.00 D)	<input type="checkbox"/> T1 <input type="checkbox"/> T2 <input type="checkbox"/> T3
2:20 PM	3:30 PM	Open Forum: Service Provider (1.00 D)	Maintenance Troubleshooting (1.00 D)	Truck Weight Education (Part 1) (1.00 I)	<input type="checkbox"/> T1 <input type="checkbox"/> T2 <input type="checkbox"/> T3
3:40 PM	4:30 PM	Enforcement 101 (1.00 D)	Open Forum: Inspection (1.00 D)	Truck Weight Education (Part 2) (1.00 I)	<input type="checkbox"/> T1 <input type="checkbox"/> T2 <input type="checkbox"/> T3

Calendar of Events

MOWA Events

January 30 – 31, 2018 – [Annual Convention & Tradeshow](#) – Arrowwood Resort, Alexandria, MN (visit www.mowa-mn.com for details)

October 21 – 24, 2018 – [NOWRA/MOWA Mega-Conference](#) – DoubleTree by Hilton, Bloomington, MN (visit www.mowa-mn.com or www.nowra.org for details).

Industry Events

February 21 – 24, 2018 - [Water & Wastewater Equipment, Treatment & Transport \(WWETT\) Show](#) at the Indiana Convention Center (visit <https://wwettshow.com/> for details).

Exhibitor Application

MOWA Onsite Wastewater Convention January 30-31, 2018--Deadline: January 5th, 2018

Company Name: _____ (As it should appear on exhibitor sign)

Contact Name: _____ **Contact Email:** _____

Preferred Mailing Address: _____

City: _____ **State/Province:** _____ **Zip/Postal Code:** _____

Country: _____ **Telephone:** (____) _____ **Fax:** (____) _____

Vendor Representatives: (2 representatives are include with each booth rental)

1st Booth: Name 1. _____ Name 2. _____

Circle days attending: Tuesday Wednesday

Tuesday Wednesday

2nd Booth: Name 1. _____ Name 2. _____

Circle days attending: Tuesday Wednesday

Tuesday Wednesday

BOOTH PREFERENCE: (See map pg 7) First Choice # _____ 2nd Choice # _____ 3rd Choice# _____ prefer not near _____

EXHIBITOR CONFERENCE FEES

1. **Booth Registration Fees:**

MOWA Member - First Booth space-\$600.00

Non-MOWA Member* – First Booth Space-\$940.00

Additional Booth Spaces: \$280.00 each

**Send in your MOWA Membership Application today and register at the member rate!*

PLEASE CHECK APPROPRIATE REGISTRATION FEES

\$600.00

\$940.00

\$280.00 X _____

Booth Registration \$ _____

2. **Scholarship Sponsorship Fees:** (see details on page 4 of vendor packet-optional)

Bronze Sponsor

\$100

Silver Sponsor

\$250

Gold Sponsor

\$500

Platinum Sponsor

\$750

Scholarship Sponsorship \$ _____

3. **Event Sponsorship:** (see details on page 4 of vendor packet-optional)

Breaks – both days:

\$250.00

Continental Breakfast – both days:

\$250.00

Roe-d-Hoe® Competition

\$250.00

Tuesday Afternoon/Evening Reception

\$250.00

Tuesday Evening Wastewater Olympics Keg of Beer*

\$425.00+ (market price)*

*In consideration of MOWA's no -alcohol policy,

*Beer Sponsorship arrangements must be made/paid for directly through vendor

Event Sponsorship \$ _____

4. **Auction item Donation or Cash Donation:** (Required for all non-Scholarship sponsors)

If you are bringing an auction item in lieu of \$50.00 please list item(s) below:

\$ 50.00 (Not required for Scholarship Sponsors!)

Auction/Scholarship donation \$ _____

LATE FEE: \$100.00 Late fee will be charged if received after January 5, 2018

Refund Policy: Written notice of cancellation must be received prior to 01/15/2018.
50% refund will be given less \$25 processing fee.

TOTAL PAYMENT DUE \$ _____

MUST BE RECEIVED BY JANUARY 5TH 2018

Payment:

Check: Payable to MOWA

Amount Paid: \$ _____

Mail to: MOWA, 5021 Vernon Ave., So., #241, Edina, MN 55436

Credit Card: Fax to (952) 487-4447, Mail to - address above, or Email to - mowacarla@aol.com

Type of Card: Visa MasterCard **Amount:** \$ _____

Credit Card # _____ Expire Date: _____ / _____ CVV Code: _____

Cardholder: _____ Signature: _____

By this signature, I authorize MOWA to process fees pertaining to this MN Onsite Wastewater Convention

I agree to indemnify and hold harmless Minnesota Onsite Wastewater Association (MOWA), from any and all liability, loss, damage, or expense from any incident which may arise while attending any portion of the 2018 MOWA Annual Convention. If applies, I authorize any photos taken of me at this event to be published in MOWA's Little Digger and/or other MOWA-related promotional materials.

Signature: _____ Date: _____

New Convention Offering: Photo Share!

MOWA Best/Worst Photo Contest

Have you ever come across a system or component that was installed so well, that you thought “Wow! Why can’t they all look like this?” Or, conversely, one so shocking that you were left wondering what was going through someone’s mind when they did it? Did you take a photo? Enter it in the 1st Annual MOWA photo contest!

Entry Procedure

1. Find your best/worst photo (one entry per person)
2. Print it out on a full page 8.5” X 11” paper (photo paper a plus)
3. Write your name and contact information on the back
4. Provide photo at the time of conference registration
5. Write a brief description on card provided at registration desk
6. Photo will be posted in a booth in the trade show where attendees can vote for their favorite
7. The top 3 photos will be announced over lunch on Wednesday and prizes award. These three photos will be printed in the next Little Digger!



Examples of the best and the worst in an SSTS world!

IN 2018, ALL ROADS LEAD TO MINNEAPOLIS!

MARK YOUR CALENDARS!

ANNOUNCING THE

2018 ONSITE WASTEWATER MEGA-CONFERENCE

OCTOBER 21-24, 2018

Doubletree by Hilton Bloomington – Minneapolis South Bloomington, MN

A partnership between NOWRA and MOWA (Minnesota Onsite Wastewater Association)

Consumer Alert: Tips to Prevent Freezing Septic Systems!

Consumer Tips To Prevent Freezing Septic Systems

The University of Minnesota has a list of seasonal tips for homeowners on how to prevent septic system freeze-ups as the winter season progresses and how to deal with them should they occur at <http://septic.umn.edu/septic-system-owners/maintenance/freezing-problems>. Here's some timely information to share with your customers.

—Place a layer of mulch 8 to 12 inches thick over the pipes, tank, and soil treatment system to provide extra insulation. This can be straw, leaves, hay or other loose material that will stay in place and not become compacted. This is particularly important for new systems that were installed so late in the year that vegetative cover didn't get established. However, if the system is currently frozen, don't add mulch now; it will delay thawing in the spring.

—Use water—the warmer the better—if you're worried your system is starting to freeze. Spread out your laundry schedule so you run one warm/hot load a day. Use the dishwasher and take hot baths. Do not leave water running all the time—this will overload the septic system.

—Going away for an extended period? Have someone use warm water in the home regularly or pump out your tank before leaving.

—Fix any leaky plumbing fixtures or appliances in your home. This will help prevent freezing problems and help your system perform better all year.

—Keep all vehicle, animal, and people traffic off the system. This is a rule to follow all year as compacted snow and soils cause frost to go down deeper and faster. Pay special attention to the area between the house and tank.

—Keep an eye on your system. If any seeping or ponding occurs, contact an onsite professional to help determine the cause and remedy.

—Add more insulation to your system. This could include replacing pipe with insulated pipe, adding expanded foam panels over septic tanks, or adding more soil cover.

If your system freezes

If your septic system freezes, call a septic system professional. The MPCA website includes a search tool for finding certified professionals in your area. Other fixes include heat tape and tank heaters, or video inspections—or worst case scenario—using the septic as a holding tank until the spring thaw.

WILLMAR PRECAST COMPANY

Products, Services & Solutions for Your Septic Installation

“Helping put money in your pocket and not down the drain.”

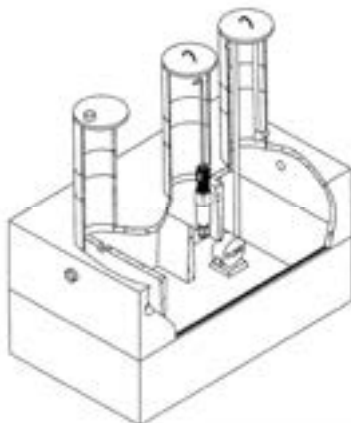

Concrete Drop Boxes

Straight 1000-3500 Gallon Septic Tanks
1500-3500 Gallon Combination Lift Tank & Septic Tank
Complete line of Zoeller pumps, gravelless drain field and filter fabric

- Complete line of tanks to accept effluent filters
- Prompt delivery on your schedule
- Entry to the tank can be made from either side or the end
- Tanks designed to conform to standards set by the Minnesota Pollution Control Agency
- Engineer designs available upon request

For ordering, pricing and other information, please contact:

Willmar Precast Company
Toll Free: 1-800-559-8527



MPCA: SSTS Reporting & Opportunity To Serve

Submitting 2017 SSTS Report information will be a “Snap”

By Cody Robinson, MPCA

It's that time of year again! The MPCA is preparing for the debut of its new SNAP survey in order to enable web-based reporting for the 2017 SSTS Annual Report. The MPCA has discussed this rollout on a number of platforms, including the SSTS Talking Tour and previous editions of this bulletin.

Some of the advantages we anticipate from the new process are more accurate, representative data statewide, and a more efficient data collection process that will allow for quicker turnaround on the SSTS Annual Report.

What should I expect?

Each LGU has identified an appropriate SSTS contact and included their email address in prior reports. Those SSTS contacts can expect an email in mid-December with a unique link to initiate the survey. Once you enter the survey, follow the given instructions and enter all data as required.

Make sure the SSTS contact information is for the individual responsible for SSTS administration within the LGU. This allows the MPCA to have accurate contact information for all LGUs across the state. If your jurisdiction contracts SSTS services through a licensed inspection business, they can be forwarded the survey, but we ask that they fill out the contact information and email for the actual SSTS administrator within the LGU.



This new process allows us to provide more detailed instruction when each question is asked, so make sure you carefully read all instructions.

The report is due back to the MPCA no later than Feb. 1, 2018, but we encourage LGUs to send reports in as soon as the questionnaire is completed. Once you have completed the survey, we strongly suggest you print and save your survey responses before submitting them to the MPCA. If you run into any issues while taking your survey, please save your progress and call Cody Robinson using the phone number provided at the bottom of each page in the questionnaire.

If you have any questions about the SSTS Annual Report, please contact Cody Robinson by email at cody.robinson@state.mn.us or by phone at 651-757-2535.

SSTS Advisory Committee, Technical Advisory Panel openings

By Aaron Jensen, MPCA

The SSTS Advisory Committee is looking to fill 10 specific roles on the committee. The committee has 21 voting members and several non-voting members. The committee meets four times per year – either in person or remotely via WebEx. The committee advises the MPCA on a wide variety of SSTS issues. The meeting time is generally from 9 a.m. to 3 p.m.

The SSTS Technical Advisory Panel (TAP) is looking to fill two openings on the committee. TAP was formed as an adjunct committee to the SSTS Advisory Committee. Its purpose is to provide technical support and recommendations to the MPCA on the product registration process for treatment and distribution products used in septic systems. The committee generally meets every other month from 10 a.m. to 3 p.m. If you are interested in filling one of these positions, contact Aaron Jensen (aaron.s.jensen@state.mn.us) for an application.

Advisory Committee Vacancies

(one in each category):

- Citizen
- Elected official
- Municipal building inspector
- County staff - SW MN
- Professional - NC MN
- Professional - NE MN
- Professional - NW MN
- Professional - SW Minnesota
- Assoc. of Home Inspector representative (*non-voting*)
- Small Business Assoc. representative (*non-voting*)

Precast Systems
Concrete Products

Serving the area for over 40 years!

116 E. Hwy. 12 • Darwin, MN 55324

Toll Free 888-693-8440

320-693-8440 • Fax: 320-693-9593

www.darwinconcrete.com

Septic Tanks
Holding Tanks
Traffic Load Rated
Grease Interceptors

Septic tanks are designed to exceed industry standards.

Guaranteed water tight.
Vacuum testing available.
Prompt Delivery.



MPCA: Rulemaking Heads-Up & Annual Report

Rulemaking starts soon on SSTS inspection/permit requirements

By Brandon Montgomery, MPCA

The MPCA is considering rule amendments that clarify when a State Disposal System (SDS) permit is required rather than a local permit, and when tank pumping is required for completion of a compliance inspection on an existing SSTS. General background information on this rulemaking can be found in previous editions of the SSTS Bulletin (May 2016, May 2017). On the web search for "MPCA SSTS Bulletin newsletter."

Sign-up with GovDelivery to receive rulemaking updates

The first public comment period related to this rulemaking process will begin in the next few weeks with a posting in the State Register. In order to stay informed of this rulemaking and to ensure you have adequate time to comment, please subscribe to the newly established GovDelivery rulemaking mailing list. Subscribing to Gov Delivery is as easy as 1-2-3.

Additionally, a rulemaking webpage has been setup providing more information on the specifics of this rule amendment and the expected schedule for this rulemaking.

2016 Minnesota SSTS Annual Report

By Cody Robinson, MPCA

The 2016 SSTS Annual Report for Minnesota is now available online (search "MPCA 2016 SSTS Annual Report"). The report summarizes information submitted by local governmental units (LGUs) such as counties, townships and cities that permit and inspect septic systems and work with local septic system pumpers, designers and installers.

The 2016 report continues to show progress toward the state's goal of identifying the location and condition of all septic systems in the state and fixing or replacing septic systems that pose a threat to human health and/or groundwater or surface waters.

In 2016, 86 counties, 86 cities, 43 townships and four other permitting authorities submitted SSTS annual report information to the MPCA. LGUs reported 4,639 new systems and 5,917 replacement systems were installed in 2016.

Since 2002, LGUs have issued 176,860 SSTS construction

The upcoming request for comments will be the MPCA's legal notice of its intent to begin rulemaking and will serve as the first of several opportunities for public comment and input on this project.

At this stage, we do not have a draft rule; we will be requesting your feedback to inform us about the ideas described on the official request for comments. If you have other ideas related to this rulemaking for us to consider, please submit them in writing. Submitting your ideas and data at this early stage in rulemaking allows us more time to address issues that may come up, and helps to ensure informed decision-making on our part.

Written comments, questions, and requests for more information on these possible rule amendments should be directed to Katie Izzo, Rule Coordinator—Minnesota Pollution Control Agency, 520 Lafayette Rd. N, St. Paul, MN 55155-4194; Telephone: 651-757-2595; Toll-free: 1-800-657-3864; or email.



Now Available Online

permits for new and replacement systems. This means that roughly 33% of Minnesota's 541,865 septic systems are less than 15 years old.

OVERLAND INSURANCE AGENCY



Our office has been the Administrating Agency for over 20 years. We know the Wastewater Industry.

Mike Overland
Nate Overland
Harold Overland

Call us for your Bonding or Insurance questions.

Phone: (888) 346-6250

Fax: (218) 346-9261

Website: <http://www.overlandinsurance.com>

255 3rd Ave SE

P.O. Box 150

Perham, MN 56573



MPCA: SSTS Amendments & Talking Tour Info

Amendments to subsurface sewage treatment systems inspection and permit requirements

This rulemaking project will amend subsurface sewage treatment system (SSTS)-related rules regarding situations where:

- A state disposal system (SDS) permit is required rather than a local permit

Under existing rules, a facility can measure its actual wastewater flows or use “table values” — values stated in rule for various types and sizes of facilities — to design a new SSTS. But in situations where measurements show a flow less than the 10,000-gallon-per-day (gpd) permit threshold, but table values indicate a flow greater than 10,000 gpd, an SDS permit is required rather than a local permit.

The MPCA is considering rule revisions to allow an existing facility to use measured values to determine permit requirements. The revisions would also include a few other modifications that capture actual wastewater flows into the environment more accurately.

- Tank pumping is required for completing a compliance inspection on an existing SSTS

The MPCA is also considering rule changes to require that a septic tank be pumped empty before an official inspection to determine its integrity. The revisions under consideration will require the tank to be inspected through a maintenance hole while empty, with the following exceptions:

1. If an inspector already knows a particular septic tank will not pass inspection for any reason, pumping the tank won't be required. However, a tank can only pass inspection if it was inspected while empty.
2. A tank integrity inspection report shows the tank has passed inspection (with the tank empty) within the past three years.

Register at GovDelivery to be notified when a rule draft is published or regarding other rulemaking activities.

SSTS Talking Tour coming to town in January

The MPCA is again hosting meetings across Minnesota where local SSTS program administrators and staff can ask questions, raise issues and discuss policy matters with the MPCA's SSTS staff. Last year, 79 jurisdictions were represented at the meetings. We are hoping for a similar turnout in 2018. Contact Aaron Jensen by email at aaron.s.jensen@state.mn.us or by phone 651-757-2544 if you have questions about the tour.

City	Date	Time	Location	Address
St. Cloud	1/3/18	1 - 4 p.m.	Stearns Co. Service Center, Room 121 B	3301 Cty Rd. 138, Waite Park
Brainerd	1/4/18	9 a.m. - 12	Crow Wing Co. Land Service Building, Meeting Rm 2	322 Laurel Street, Brainerd
Marshall	1/3/18	1 - 4 p.m.	Lyon Co. Public Works Building, downstairs room	504 Fairgrounds Rd., Marshall
Benson	1/4/18	9 a.m. - 12	Swift Co. Attorney's Office	211 11th St. N., Benson
Grand Rapids	1/9/18	1 - 4 p.m.	Itasca Co. Courthouse, Rm. 1135	123 NE 4th St. Grand Rapids
Duluth	1/10/18	1 - 4 p.m.	MPCA offices - Duluth, Small Conference Rm	525 Lake Ave. S., Suite 400, Duluth
Pine City	1/11/18	9 a.m. - 12	Pine Co. Courthouse - County Board Rm.	635 Northridge Dr. NW, Pine City
Detroit Lakes	1/9/18	1 - 4 p.m.	MPCA offices - Detroit Lakes, Main Floor Rm.	714 Lake Ave., Detroit Lakes
Thief River Falls	1/10/18	1 - 4 p.m.	Pennington SWCD Office	201 Sherwood Ave.S., Thief River Falls
Bagley	1/11/18	9 a.m. - 12	Clearwater Co. Courthouse	213 Main Ave. N., Bagley
Mankato	1/16/18	1 - 4 p.m.	Government Center Building, Valley Rm. 3rd Floor	410 5th St. S., Mankato
Rochester	1/17/18	1 - 4 p.m.	MPCA Offices - Rochester, Large Conference Rm.	18 Wood Lake Drive Se., Rochester
St. Paul	1/23/18	1 0 4 p.m.	MPCA Offices - St. Paul 100, First Floor	520 Lafayette Rd. N., St. Paul

MPCA third quarter enforcement actions included two involving SSTS

During the period of July - September, 2017, the MPCA completed 30 enforcement cases. Two of the 30 cases (7 percent) were SSTS related. They were located in Taopi (\$1,000), and Canton (\$1,000).



THE PERFECT FIT EVERY TIME!

We heard you! Polylok now offers risers in 2" and 3" heights. Whether you are working with a septic tank, distribution box or drainage box, stacking these new heights with our existing series of 6" and 12" risers will enable you to get the perfect fit every time!

Worried about safety? We are too! That's why you can install a concrete plug in our 20" and 24" riser pans. Additionally, we offer 12", 20" and 24" riser safety screens that provide a secondary layer of protection.

RISER SAFETY ACCESSORIES



Safety Screens
 (12") 3017-SS
 (20") 3009-SS
 (24") 3008-SS

Lid-Lok Safety Device
 (20") 3009-LOK
 (24") 3008-LOK



24" Dual Safety Cover
 3009-KYDC



24" x 2" Riser
 3008-GR2



20" x 2" Riser
 3009-GR2



20" x 3" Riser / Riser Pan
 3009-LPRP

OTHER SIZES AVAILABLE

- 24" x 3" Riser / Riser Pan - 3008-RP
- 24" x 6" Riser - 3008
- 24" x 12" Riser - 3008-R12
- 20" x 6" Riser - 3009
- 20" x 12" Riser - 3009-R12
- 20" Riser Pan - 3009-RP
- 12" x 6" Riser - 3017-R



1-877-765-9565 / www.polylok.com

For more information call or visit our website today!



MPCA: Consumer Education can be magnetic

Magnets draw homeowner's attention to septic maintenance

MPCA SSTS staff are committed to empowering Minnesota homeowners to understand and maintain their septic systems in order to protect human health, and groundwater and surface waters, not to mention the significant financial investment a septic system represents.

Earlier in 2017, the MPCA produced and distributed approximately 24,500 "This Home Has a Septic System" magnets to local government units (LGUs) across the state, and to people visiting the Eco Experience at the Minnesota State Fair.

These magnets serve as a great tool for sparking conversations with homeowners about SSTS maintenance, and provide tips to help maintain a healthy septic system.

Letters sent to LGUs with their magnets suggested they include the magnets with newly issued permits. The number of magnets each LGU received was based on the number of permitted systems they reported through the Annual Report.

The MPCA has approximately 8,000 magnets remaining, and will be discussing how to best get these in the hands of SSTS homeowners moving forward. As the MPCA does not have funding available to produce these magnets year after year, we

strongly encourage local units of government to consider having more personalized magnets created for their areas.

Cody Robinson has information on the vendor used by the MPCA, and can provide a templates to assist those who wish to create their own version of the magnet.

Contact him via email, cody.robinson@state.mn.us, or by phone at 651-757-2535 for more information.

This Home Has a Septic System

Septic System Description
 Tell us the approximate location, or be that part of the system, of an individual septic system. For more details, contact the county you live in.

Septic system located: _____

Tank size: _____ gallons

Capacity: _____ beds/bathrooms

(Your logo here)

Things to keep in mind:

- ONLY human waste and toilet paper may be flushed. NEVER flush animal medications, "flushable" wipes, facial tissue, or feminine hygiene products. Failure to do so could lead to costly repairs or replacement of your system.
- Do your best to conserve water and fix leaky fixtures as soon as possible.
- Regularly inspect your system and ensure maintenance files are current.
- Most systems require routine pumping at least every three years.
- Do not drive or park vehicles on any part of your septic system.
- Contact a licensed professional if you have questions or concerns about your sewage tank or infiltration.

Septic System Pumping Record
 Use a licensed professional to determine when the septic tank should be pumped per your system.

Date	Pumping Expense/Phone Number	Next Service Due (YYYY)
1/1/20	Sam Pumpford Co. (313) 555-2234	1/1/20

Please don't pump your septic tank yourself.

Preview: Truck Weight Regs, Continued from Page 1

provide information and explanations to attendees on how to haul the greatest legal weight, without violating the truck-weight laws. How you configure your truck, with proper axle spacing and tire size, makes a difference.

Features

- A clickable, county-level Minnesota state map for finding basic county-level truck weight information, including restrictions for bridges and seasonal loads
- A schedule for upcoming Minnesota Truck-Weight Compliance Training workshops
- Links to key resources for state and national information on load restrictions, permits, and regulations
- Sample truck-weight calculations
- Training videos [Roads and Loads: Finding a Balance](#) and [How Heavy Is Too Heavy](#)
- Minnesota educational presentation (1.30 MB PDF) to safeguard public roadways through voluntary vehicle weight compliance

The resources found here may be especially useful to trucking entities, scale operators, farm truck owners and operators,

aggregate haulers, truck manufacturers, township and county authorities, new truck dealers, out-of-state companies bound by Minnesota's legal weight limits, and truck driving students.

Course Instructors

This program is presented by the Alexandria Technical and Community College. Instructors include:

- Greg Hayes, Program Development and Support
- Tom J. Nelson, Training Coordinator and Instructor
- Paul Robischon, Instructor
- Keith Williamson, Instructor

This educational course was developed by Greg A. Hayes in 2001 to help anyone understand the technical criteria of the truck weight laws in Minnesota. For questions regarding course content, please contact Greg Hayes at 218-684-1764 or GAHayes@gmail.com or Tom J. Nelson at 320-828-1809 or Thomas.Nelson@alextech.edu.

Tom Nelson will be presenting on this topic at our Winter Convention in Alexandria. Please see Page 6 of this issue for schedule.

Convention Highlight: Septics and CECs

Contaminants of emerging concern: Pharmaceuticals and Personal Care Products

People and industry use tens of thousands of chemicals in industrial and household products and applications. A vast array of these chemicals have been found in the environment, where we consider them contaminants of emerging concern or CECs. Most of these CECs have not been fully evaluated for the risks they might pose to the environment, to plants, fish, wildlife — or to us.

Where do we find CECs? MPCA and other researchers have been looking for CECs in surface water, wastewater effluent, groundwater, stormwater, and fish for over a decade. Monitoring for these compounds can help us understand to what extent these contaminants are entering the environment.

So what's the big deal? Chemicals present in the environment may have a variety of adverse impacts on aquatic life...and we don't know much about the risks these contaminants pose to ecological health, or how concerned we should be relative to other environmental concerns...

What is the MPCA doing to reduce pollution? The MPCA has been investigating Minnesota's lakes, rivers, and groundwater to determine how common these CECs are in the environment. This work has shown that chemicals in the

medicines we take, in our shampoos, lotions and detergents, and other familiar products are found widely in Minnesota waters, though at low concentrations.

How can consumers make a difference? The choices we make every day may have long-term consequences for ecological health. There are many ways consumers can reduce their personal impact on our valuable aquatic resources as well as on groundwater and septic systems. Here are just a few examples:

- Dispose of medications properly
- Avoid products with microplastics
- Reduce chemical use in your home
- Avoid using antibacterial soap

For more information about how to identify the impact pharmaceuticals and personal care products are having on septic systems and how to troubleshoot the system, attend the MOWA Convention presentation, **Pharmaceuticals and Personal Care Products - What You Need to Know**, on Tuesday, January 30th. For registration information on this valuable session, go to Page 6.

BUILD STRONG — BUILD SAFE

With Precast Tanks to 40,000 Gallons



- Quality- Engineered
- Superior Construction
- Easy Installation
- Septic, Holding, Grease
- HS-20 Traffic Loading Tanks Available
- Latest Technologies
- Guaranteed Water Tight
- Vacuum Testing Available

Providing
Complete
Underground
Precast
Solutions!



Wieser Concrete has precast solutions for every underground project from basic manholes to custom designed storm water applications.

WIESER CONCRETE
Innovation, Quality
and Service since 1965

www.wieserconcrete.com



SERVING ALL OF MINNESOTA

Maiden Rock, WI
Jordan, MN

800-325-8456
877-746-6211

"Where Quality is a Standard Not an Extra"

2018 OSTP Certification Course Descriptions and Offerings

Introduction to Onsite Systems (15 Direct Credits)

Fee: \$360 Exam: Yes

This 15-hour workshop is the foundation for all SSTS certification courses and is best completed prior to the other workshops. It prepares participants for the Basic exam and provides an overview of onsite treatment options and concepts. Enrollment in this workshop includes a copy of the Manual for SSTS Professionals in Minnesota.

Topics include:

- Treatment of wastewater
- Site evaluation
- Wastewater characteristics
- Soil treatment systems

10-1	Grand Rapids - Sawmill Inn	1/8-10/18	Deadline: 1/2/18
10-2	St. Cloud - Moose Lodge	3/19-21/18	Deadline: 3/12/18
10-3	Mankato - AmericInn	11/12-14/18	Deadline: 11/5/18

Installing Onsite Systems (12 Direct Credits)

Fee: \$265 Exam: Yes

This 12-hour workshop prepares attendees for the Installer exam and provides information about proper installation practices.

PREREQUISITE: Introduction to Onsite Systems

Topics include:

- Construction planning
- Tools for installing
- Construction practices
- Pipelayer certification

112-1	Grand Rapids - Sawmill Inn	1/11-12/18	Deadline: 1/4/18
112-2	St. Cloud - Moose Lodge	3/22-23/18	Deadline: 3/15/18
112-3	Mankato - AmericInn	11/15-16/18	Deadline: 11/8/18

Basic Design of Onsite Systems (21 Direct Credits)

Fee: \$440 Exam: Yes

This 21-hour workshop teaches attendees to properly design various septic systems in preparation for the Basic Designer exam. Enrollees must have the current manual to use during the workshop. Onsite Manuals are available for \$50.

PREREQUISITE: Introduction to Onsite Systems

Topics include:

- Flow determination
- Tank design
- System design
- Pumps and pressure design

20-1	Mankato - AmericInn	2/13-16/18	Deadline: 2/6/18
20-2	Grand Rapids - Sawmill Inn	4/17-20/18	Deadline: 4/10/18

Intermediate Design & Inspection of Onsite Systems

(21 Direct Credits) Fee: \$440 Exam: Yes

This 21-hour course prepares individuals for the Intermediate Design and Inspection exam. Intermediate Designers can design Type I - IV systems for domestic strength wastewater up to 2,500 gpd. Intermediate Inspectors can review these designs, inspect these systems, and administer on-going compliance with their operating permits. Enrollment in this workshop includes copies of the MPCA Design Guidance.

PREREQUISITE: Full Certification as a Basic Designer or Inspector; Repeating the OSTP Basic Design course is highly recommended and can be counted as continuing education.

Topics include:

- ATUs
- Media filter applications
- Flow equalization
- Soil treatment design reductions

27-1	Alexandria - Douglas County Public Works Building	2/27-3/2/18	Deadline: 2/20/18
------	--	-------------	-------------------

Advanced Design & Inspection of Onsite Systems

(21 Direct Credits) Fee: \$440 Exam: Yes

This 21-hour course includes a field portion and focuses on the design and inspection of Type IV systems with flows greater than 2500 gpd. This course explores high strength waste, site assessment techniques, and prepares participants for the Advanced Design exam.

PREREQUISITE: Full Certification as a Basic Designer or Inspector and successful completion of Intermediate exam.

Topics include:

- Collection system design
- Nitrogen & phosphorus removal
- Groundwater mounding
- High strength waste

29-1	Alexandria - Douglas County Public Works Building	3/27-30/18	Deadline: 3/20/18
------	--	------------	-------------------

Inspecting Onsite Systems (12 Direct Credits)

Fee: \$265 Exam: Yes

This 12-hour workshop identifies Minnesota requirements for existing and new system inspections and prepares participants for the Inspector exam.

PREREQUISITE: Introduction to Onsite Systems.

Topics include:

- Administrative requirements
- New system inspection
- Existing system inspection
- Tools and procedures

30-1	Alexandria - Douglas County Public Works Building	6/6-7/18	Deadline: 5/30/18
------	--	----------	-------------------

Maintaining Onsite Systems (15 Direct Credits)

Fee: \$310 Exam: Yes

This 15-hour workshop gives participants an overview of system management, the federal requirements for land application of septage, and prepares people for the Maintainer exam.

PREREQUISITE: Introduction to Onsite Systems

Topics include:

- Land application rates
- Record keeping
- Maintaining Type I SSTS
- Soil survey use

415-1	Alexandria - Douglas County Public Works Building	4/2-4/18	Deadline: 3/26/18
-------	--	----------	-------------------

Service Provider (21 Direct Credits)

Fee: \$490 Exam: Yes

This 21-hour workshop prepares attendees for the Service Provider exam and offers an in-depth look into the care of all system types. This course is based on the National O&M Service Provider materials and will include a field component. It is intended for system maintainers, designers or MPCA certified operators who need training for soil-based system management.

PREREQUISITE: Introduction to Onsite Systems

Topics include the management of:

- Type I O&M
- Type IV O&M
- Collection system O&M
- System troubleshooting

49-1	Mankato - AmericInn	5/1-4/18	Deadline: 4/24/18
------	---------------------	----------	-------------------

Soils (15 Direct Credits)

Fee: \$310 or \$475 with Munsell Color Guide Exam: Yes

This 15-hour workshop prepares attendees for the Soils exam and provides participants with a detailed understanding of how particular soils affect the treatment of sewage. Participants will also receive instruction at a field location. Munsell Color Guides are available for \$165 and Sand Cards for \$10. This class does NOT meet the 6-hour soils continuing education requirement for all Designer and Inspector categories.

PREREQUISITE: Introduction to Onsite Systems

Topics include:

- Percolation testing
- Soil characteristics
- Field evaluations
- Soil survey use

515-1	Grand Rapids - Sawmill Inn	5/22-24/18	Deadline: 5/15/18
515-2	Faribault - Rice County Gov't Services Center	6/12-14/18	Deadline: 6/5/18

Enroll online: septic.umn.edu

2018 OSTP Continuing Education Course Descriptions and Offerings

Installer Continuing Education (12 Direct Credits)

Fee: \$265 Exam: No

This 12-hour workshop will meet the continuing education requirements for any certification but is specifically tailored for Installers. All information will be provided from the perspective of a system installer.

Topics Include:

- Construction safety
- Keys to proper installation
- Pumps and dosing
- Rule change implications

69-1	St. Cloud - Moose Lodge	1/22-23/18	Deadline: 1/16/18
69-2	Mankato - Americlenn	3/6-7/18	Deadline: 2/27/18
69-3	Grand Rapids - Sawmill Inn	12/6-7/18	Deadline: 11/29/18

General Continuing Education (12 Direct Credits)

Fee: \$265 Exam: No

This 12-hour workshop is designed to meet the continuing education requirement for SSTS professional registration. The topics will be varied to give a wide range of information for SSTS professionals.

Topics include:

- Rule change implications
- Pressure distribution
- Working on difficult sites
- MPCA update

60-1	Cloquet Forestry Center	1/4-5/18	Deadline: 12/27/17
60-2	St. Cloud - Moose Lodge	2/19-20/18	Deadline: 2/12/18
60-3	Alexandria - Douglas County Public Works Building	11/6-7/18	Deadline: 10/30/18
60-4	Mankato - Americlenn	12/11-12/18	Deadline: 12/4/18

Maintainer Continuing Education (12 Direct Credits)

Fee: \$265 Exam: No

This 12-hour workshop is specifically designed as continuing education for those involved in maintaining septic systems.

Topics include:

- 503 regulations
- Troubleshooting
- System care
- Other establishments

46-1	St. Cloud - Moose Lodge	4/4-5/18	Deadline: 3/29/18
------	-------------------------	----------	-------------------

Design/Inspector Continuing Education (12 Direct Credits)

Fee: \$265 Exam: No

This 12-hour workshop is designed to meet the continuing education requirement of SSTS professional holding a designer and/or inspector certification. The course is will focus on design and inspection issues.

Topics include:

- Rule/policy updates
- Commercial systems
- How to add capacity
- Challenging inspections
- System design with new forms

82-1	Mankato - Americlenn	4/12-13/18	Deadline: 4/5/18
------	----------------------	------------	------------------

SSTS Design Forms Training Continuing Education (4 Direct Credits)

Fee: \$100 Exam: No

This 4-hour workshop will review and use the current design forms for completing and submitting a new system design. This will allow for people that are new to the use of the design forms to have a hands-on look of the forms. This workshop will be in a computer lab and have limited enrollment.

Topics include:

- Design forms
- Management plans
- Preliminary and field evaluation forms

21-1	Cologne - Carver County Public Works	1/18/18	Deadline: 1/11/18
------	---	---------	-------------------

Soils Continuing Education (6 Soils-Specific Direct Credits)

Fee: \$240 or \$405 with Munsell Color Guide Exam: No

This 6-hour course couples classroom and field training to meet soils-specific MPCA continuing educational requirements for designers and inspectors. Munsell Color Guides are available for \$165 and Sand Cards for \$10.

Topics include:

- Regional geology and soils
- Local soil hydrology information
- Soils observations
- System siting and design

55-1	St. Cloud - Moose Lodge	5/15/18	Deadline: 5/7/18
55-2	Rushford - MiEnergy Co-op	6/19/18	Deadline: 6/12/18
55-3	Pine City - Pine County Courthouse	6/28/18	Deadline: 6/21/18
55-4	Fergus Falls - Otter Tail County Gov't Services Center	7/12/18	Deadline: 7/5/18
55-5	Grand Rapids - Sawmill Inn	7/24/18	Deadline: 7/17/18
55-6	Two Harbors - Superior Shores Resort	9/6/18	Deadline: 8/30/18
55-7	Waseca - Southern Research and Outreach Center	10/10/18	Deadline: 10/3/18

Design Field Day Continuing Education

(6 Direct Credits) Fee: \$150 Exam: No

This 6-hour workshop combines a classroom and field component to discuss the process of design. The course will review the requirements for designing a system and the required aspects to be submitted to the LGU. The field portion will be an evaluation of the soil characteristics and completion of the design report.

Topics include:

- Required design steps
- System loading
- Working with elevations
- Soil applications and concerns

63-1	Grand Rapids - Sawmill Inn	7/25/18	Deadline: 7/18/18
------	----------------------------	---------	-------------------



Enroll online: septic.umn.edu

Onsite Sewage Treatment Program 2018 Certification Classes and Continuing Education

Visit septic.umn.edu for easy online registration • Enroll early - registration is limited • All courses begin at 8 a.m. unless otherwise noted

INTRODUCTION TO ONSITE SYSTEMS \$360 *Includes manual*

- 10-1 Grand Rapids 1/8-1/10/2018 Deadline: 1/2/2018
- 10-2 St. Cloud 3/19-3/21/2018 Deadline: 3/12/2018
- 10-3 Mankato 11/12-11/14/2018 Deadline: 11/5/2018

INSTALLING ONSITE SYSTEMS \$265 *Manual included w/Intro

- 112-1 Grand Rapids 1/11-1/12/2018 Deadline: 1/4/2018
- 112-2 St. Cloud 3/22-3/23/2018 Deadline: 3/15/2018
- 112-3 Mankato 11/15-11/16/2018 Deadline: 11/8/2018

BASIC DESIGN OF ONSITE SYSTEMS \$440

- 20-1 Mankato 2/13-2/16/2018 Deadline: 2/6/2018
- 20-2 Grand Rapids 4/17-4/20/2018 Deadline: 4/10/2018

INTERMEDIATE DESIGN AND INSPECTION \$440

- 27-1 Alexandria 2/27-3/2/2018 Deadline: 2/20/2018

ADVANCED DESIGN AND INSPECTION \$440

- 29-1 Alexandria 3/27-3/30/2018 Deadline: 3/20/2018

INSPECTING ONSITE SYSTEMS \$265

- 30-1 Alexandria 6/6-6/7/2018 Deadline: 5/30/2018

MAINTAINING ONSITE SYSTEMS \$310

- 415-1 Alexandria 4/2-4/4/2018 Deadline: 3/26/2018

SERVICE PROVIDER \$490 (includes CIDWT O/M Manual)

- 49-1 Mankato 5/1-5/4/2018 Deadline: 4/24/2018

SOILS \$310/\$475 with Munsell Color Guide

- 515-1 Grand Rapids 5/22-5/24/2018 Deadline: 5/15/2018
- 515-2 Faribault 6/12-6/14/2018 Deadline: 6/5/2018

INSTALLER CE \$265

- 69-1 St. Cloud 1/22-1/23/2018 Deadline: 1/16/2018
- 69-2 Mankato 3/6-3/7/2018 Deadline: 2/27/2018
- 69-3 Grand Rapids 12/6-12/7/2018 Deadline: 11/29/2018

GENERAL CE \$265

- 60-1 Cloquet 1/4-1/5/2018 Deadline: 12/27/2017
- 60-2 St. Cloud 2/19-2/20/2018 Deadline: 2/12/2018
- 60-3 Alexandria 11/6-11/7/2018 Deadline: 10/30/2018
- 60-4 Mankato 12/11-12/12/2018 Deadline: 12/4/2018

MAINTAINER CE \$265

- 46-1 St. Cloud 4/4-4/5/2018 Deadline: 3/29/2018

DESIGN CE/INSPECTOR CE \$265

- 82-1 Mankato 4/12-4/13/2018 Deadline: 4/5/2018

SSTS DESIGN FORMS TRAINING CE \$100

- 21-1 Cologne 1/18/2018 Deadline: 1/11/2018

SOILS CE \$240/\$405 with Munsell Color Guide

- 55-1 St. Cloud 5/15/2018 Deadline: 5/7/2018
- 55-2 Rushford 6/19/2018 Deadline: 6/12/2018
- 55-3 Pine City 6/28/2018 Deadline: 6/21/2018
- 55-4 Fergus Falls 7/12/2018 Deadline: 7/5/2018
- 55-5 Grand Rapids 7/24/2018 Deadline: 7/17/2018
- 55-6 Two Harbors 9/6/2018 Deadline: 8/30/2018
- 55-7 Waseca 10/10/2018 Deadline: 10/2/2018

DESIGN FIELD DAY CE \$150

- 63-1 Grand Rapids 7/25/2018 Deadline: 7/18/2018

Please do not staple or cut the checks or form!

1. *EMAIL _____

2. *NAME _____
Please Print First Middle Initial Last

3. *PREFERRED ADDRESS _____

4. *CITY _____ 5. *STATE _____ 6. * ZIP _____

Home
 Business

7. COMPANY _____

8. *PHONE (_____) _____

10. PAYMENT OPTION Check or Money Order Local Government PO attached
*Indicates required field

Total for selected workshops:	\$ _____
Late fee (\$45 per workshop):	\$ _____
Updated Manual (\$50):	\$ _____
<small>A manual is provided with enrollment in Introduction to Onsites; Purchase only if you want the 2011 version (purple cover).</small>	
Munsell Color Book (\$165):	\$ _____
<small>Recommended for Soils and Soils CE courses</small>	
Sand Card (\$10):	\$ _____
<small>Recommended for Soils and Soils CE courses</small>	
Total Amount Due:	\$ _____

Payment is required to reserve a spot in any course.

Confirmation with instructions will be
EMAILED along with a receipt.

Questions?
Call: 1-800-322-8642

PLEASE MAIL ENROLLMENT FORMS TO :
University of Minnesota OSTP
173 McNeal Hall
1985 Buford Avenue
St. Paul, MN 55108

MAKE CHECKS PAYABLE TO:
Regents of the University of Minnesota

Enroll online: septic.umn.edu

The is a bi-monthly publication of the Minnesota Onsite Wastewater Association

Editor: Carla Tourin E-mail: MOWAcarla@aol.com

The articles printed in the publication do not necessarily reflect the opinion of this organization. Readers are encouraged to respond to the articles with their own points-of-view. We welcome industry-related comments or articles. Information or inquiries should be sent to any of the following: MN Onsite Wastewater Association, MOWA, 5021 Vernon Ave, So., Suite 241, Edina, MN 55436 Phone: 612.801.5897 Fax: 952.487.4447 Website: www.mowa-mn.com



2018 MOWA MEMBERSHIP APPLICATION

Membership: Renewal New Member

- Individual Member \$240 (1 person)
 Business Group /Government Unit \$340 (up to 5 people; \$100 /person after 5)
 Student \$140 (1 person)
 Life-time Honorary

Note: Your MOWA Membership includes one NOWRA membership

Memberships are based on calendar year - After July 1st, new members pay \$140-individual / \$190-business or gov't groups for remainder of 2018

Individual/Group Contact: This person will be listed as the NOWRA member on the Septic Locator website. They will be listed first in all MOWA publications. Please print clearly.

• 1st Member _____ Company Name _____
 Address _____ City/State/Zip _____
 Title _____ Phone _____ Mobile/800# _____ Fax _____
 Email _____ Website _____ County _____

Circle the counties you work in: Needed for Directory and website.

Statewide..... 88	Clay 14	Hubbard 29	Marshall 44	Pipestone 59	Steele 74
Aitkin..... 1	Clearwater 15	Isanti 30	Martin 45	Polk 60	Stevens 75
Anoka 2	Cook 16	Itasca 31	McLeod 46	Pope 61	Swift 76
Becker 3	Cottonwood 17	Jackson 32	Meeker 47	Ramsey 62	Todd 77
Beltrami 4	Crow Wing 18	Kanabec 33	Mille Lacs 48	Red Lake 63	Traverse 78
Benton 5	Dakota 19	Kandiyohi 34	Morrison 49	Redwood 64	Wabasha 79
Big Stone 6	Dodge 20	Kittson 35	Mower 50	Renville 65	Wadena 80
Blue Earth 7	Douglas 21	Koochiching 36	Murray 51	Rice 66	Waseca 81
Brown 8	Faribault 22	Lac qui Parle Lake 37	Nicollet 52	Rock 67	Washington 82
Carlton 9	Fillmore 23	Lake 38	Nobles 53	Roseau 68	Watsonwan 83
Carver 10	Freeborn 24	Lake of the Woods 39	Norman 54	Scott 69	Wilkin 84
Cass 11	Goodhue 25	Le Sueur 40	Olmsted 55	Sherburne 70	Winona 85
Chippewa 12	Grant 26	Lincoln 41	Otter Tail 56	Sibley 71	Wright 86
Chisago 13	Hennepin 27	Lyon 42	Pennington 57	St. Louis 72	Yellow Medicine 87
	Houston 28	Mahnomen 43	Pine 58	Stearns 73	

Information: (Check all that apply)

- Installer Pumper Designer Inspector Gov't Regulator Educator Service Provider Student
 Soil Scientist Professional Engineer Manufacturer Operator/Maintenance Supplier Other: _____

Additional Business/Government Members:

• 2nd Member _____ Title _____ County _____
 Address _____ City/State/Zip _____
 Phone _____ Mobile/800# _____ Fax _____ Email _____
 • 3rd Member _____ Title _____ County _____
 Address _____ City/State/Zip _____
 Phone _____ Mobile/800# _____ Fax _____ Email _____
 (Please list additional business/government group members on separate sheet with complete contact information.)

Publications: Would you prefer receiving 'Little Digger' newsletters via ... Regular Mail Electronically
 We currently send one publication per address to business/government groups. Contact the MOWA office if you'd like additional copies.

Additional NOWRA Memberships: MOWA membership fees include one NOWRA membership per company/organization. List names of members who want additional NOWRA memberships here: Cost - \$40 per person.

2) _____ 3) _____ 4) _____ 5) _____

Payment: (Please print) MOWA Membership \$ _____ + Add'l NOWRA Memberships = **Amount: \$** _____
 Check enclosed (Payable to MOWA) VISA MasterCard
 Card Number: _____ CVV: _____ Expiration Date: _____ Cardholder Name: _____
 Signature: _____ Date _____

MOWA, 5021 Vernon Ave, So., Suite 241, Edina, MN 55436 Phone: 612.801.5897 Fax: 952.487.4447

Note: Dues payable to MOWA are not deductible as a charitable contribution but may be deductible as an ordinary and necessary business expense. MOWA estimates that 10% of your MOWA dues are used for governmental affairs issues and therefore are not deductible.



Presorted
Standard
U.S. Postage
PAID
Rochester, MN
Permit No. 289

MOWA

5021 Vernon Ave, So., Suite 241
Edina, MN 55436
Phone: 612.801.5897
Fax: 952.487.4447

RETURN SERVICE REQUESTED

www.mowa-mn.com

MySpy™ WiFi Messenger

The MySpy™ WiFi Messenger system uses your existing WiFi or Ether network to monitor and report any residential alarm condition, including sump high water level (float switch), or under/over temperature conditions. The alarm sends text and/or email notifications to your smartphone, tablet or computer providing you peace of mind 24/7. Easy installation and setup! Visit www.mywifialarm.com to learn more.

- ✓ Peace of Mind 24/7
- ✓ WiFi Monitoring
- ✓ Email/Text Notifications
- ✓ No Monthly Fees
- ✓ Battery Backup



SJE Rhombus

www.sjrhombus.com

