

2020

MOWA CONVENTION & EXHIBITOR SHOWCASE

EVOLUTION
OF ONSITE WASTEWATER
TREATMENT

JANUARY 28TH - 29TH, 2020



MANKATO
CIVIC CENTER

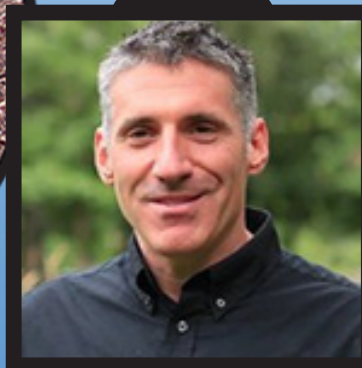

MONDAY, JANUARY 27TH
Conference Kick-Off
Pub 500

RENOWNED SPEAKER
Climatologist Kenneth
Blumenfeld!

TUESDAY, JANUARY 28TH
VENDOR SHOW
Appetizers, Games, Prizes!



**CASINO
NIGHT!**

**SILENT AND LIVE
AUCTIONS!**

**AWARDS
BANQUET!**

www.mowa-mn.com

Sponsored by MOWA In Cooperation with the University of Minnesota,
and the Minnesota Pollution Control Agency

MORE CHOICES. MORE CONFIDENCE.



CAT 320 GC

CAT 320

CAT 323

No one knows better than you do that to get more done at the lowest possible cost requires confidence in your crew and equipment choices. Next Generation Cat® Excavators offer unique combinations of features that you can match to your work's productivity and cost targets. What kind of results can you expect?

UP TO **45%**
MORE EFFICIENCY

UP TO **25%** LESS
FUEL CONSUMPTION

UP TO **15%** LOWER
MAINTENANCE COST

CONTACT US TODAY ABOUT THE NEW RANGE OF EXCAVATOR CHOICES AND WHICH ONE IS RIGHT FOR YOU.

MORE DETAILS AND SPECIFICATIONS ARE AVAILABLE AT ZIEGLERCAT.COM.

© 2018 Caterpillar. All Rights Reserved. CAT, CATERPILLAR, BUILT FOR IT, their respective logos, "Caterpillar Yellow", the "Power Edge" trade dress as well as corporate and product identity used herein, are trademarks of Caterpillar and may not be used without permission.



From MOWA's Executive Director



By **Pat Martyn, MOWA Executive Director**

We are happy to announce it is Convention Time! Our Annual Convention and the great Minnesota septic get together is coming up on January 28th and 29th, 2020 at the Mankato Civic Center.

This year, back by popular demand, we are offering a two-day format, but rest assured you can still get your CEUs, along with the same networking opportunities and fun events that our Convention Committee has put together. In addition to our great presenters, we are pleased to offer a social event on Monday evening, as well as a Banquet and Casino Night following our trade show. We will also hold our silent and live auctions. Elsewhere in this edition you will find sponsorship opportunities.

This year, more than ever, a sponsorship as our its coffers following a hold a convention. The that we hosted the Mega- which took the place of our

You can find information edition of the Little Digger.

and exhibitor registration forms on Pages 9-10 that you can use. There are other ways of registering as well, so choose the one that works best for you. Even if you have to call the office directly, we will get it done.

Year after year, MOWA members cite the benefits of attending the convention where they have the opportunity to mingle with friends and colleagues in the industry, hash out items of interest, catch up on news or just have friendly conversations. Exhibits hosted by the sponsors and reputable vendors present the best products available.

Everyone should take advantage of the fact that our state regulators from the Minnesota Pollution Control Agency attend the show. You can gain valuable insights into their enforcement responsibility, or ask a question that has been puzzling to you.

And lastly, MOWA staff and its Board want to recognize our departing Board members as their terms end in 2020. Their generous contribution of time and expertise has been an invaluable addition to the organization.

As these Board members retire, positions on the Board of Directors become open. Do you want to play a more involved role in Board decision making process? Let us know if you are interested in running for a spot on the Board. Elections are held at the Convention, and we are looking for a few good people to fill the posts of departing Board Members. ■

Calendar of Events

MOWA Events

January 28th – 29th, 2020 – 2020 Annual Convention and Tradeshow- Mankato Civic Center, Mankato.

Industry Events

February 17 – 20, 2020 – WWETT Show – Indiana Convention Center

MOWA

2019 BOARD OF DIRECTORS

Mike Capra, President

Capra's Utilities

mike@capras.com

651-762-2500

Travis Johnson, President-Elect

Infiltrator Water Technologies

tjohnson@infiltratorwater.com

320-362-0962

Andy Winkler, Past-President

Wieser Concrete

winkler@wieserconcrete.com

715-647-2311

Dean Flygare, Past-President

Flygare Excavating, Inc.

deanflygare@gmail.com

320-980-3856

Cindy Tiemann, Secretary

Fiedler's Your Pumping Specialists

cindy@fiedlerpumping.com

320-252-9916

Pete Otterness, Treasurer

Nicollet County

pete.otterness@co.nicollet.mn.us

507-934-7076

Stacey Feser

Feser Environmental

staceyfeser@gmail.com

612-382-7491

Chris LeClair

Otter Tail Land & Resources

cleclair@co.ottertail.mn.us

218-998-8105

Bernie Miller

Miller's Sewage Treatment Solutions

bernie@millerssewage.com

320-398-2705

Alex Pepin

Ten Thirty Environmental Solutions

alex.pepin@tenthyenvironmental.com

612-248-4281

Ben Rynda

Advanced Septic Solutions, Inc.

rynd1686@gmail.com

612-298-6920

Matt Summers

Wenck Associates

msummers@wenck.com

651-395-5206

The is a bi-monthly publication of the Minnesota Onsite Wastewater Association

Editor: Carla Tourin E-mail: MOWAcarla@aol.com

The articles printed in the publication do not necessarily reflect the opinion of this organization. Readers are encouraged to respond to the articles with their own points-of-view. We welcome industry-related comments or articles. Information or inquires should be sent to any of the following: MN Onsite Wastewater Association, MOWA, 5021 Vernon Ave, So., Suite 241, Edina, MN 55436 Phone: 612.801.5897 Fax: 952.487.4447 Website: www.mowa-mn.com



A Convention Message for MOWA Members!

Dear Convention Attendee:

The Minnesota Onsite Wastewater Association, in cooperation with the University of Minnesota and the Minnesota Pollution Control Agency, will present the 2020 Minnesota Onsite Wastewater Convention Tuesday, January 28th and Wednesday, January 29th, 2020! We will be convening the 2020 convention at the state-of-art Mankato Civic Center, where we will offer over 30 booths at our tradeshow on Tuesday.

This year, in response to your feedback, we will once again offer a two-day convention format. The 2020 conference theme is "Evolution of Onsite Wastewater Treatment." We are very pleased to announce that our keynote speaker is Kenny Blumenfeld, Senior Climatologist with Minnesota DNR State Climatology Office, who will be presenting on "Septic System Impacts Due to Climate Change." We will feature presentations on Policy, Freezing Issues, Design & Installation, Type III and IV Systems, Tanks & Risers, and Business & Safety, as well as our popular Open Forums and Panel discussions. We will also continue to offer the MPCA Retest and the Tank Manufacturers' meeting.

In addition to our tradeshow on Tuesday, we will be holding our annual auction to benefit the Tony Ruppert Scholarship Fund, as well as offering sponsorship opportunities for Attendees. We are also very excited to offer a Banquet and Casino Night on Tuesday evening—all included in the price of admission! Those of you who are arriving on Monday night are invited to join us for a Social Evening at downtown Mankato's Pub 500.

Why join us at the 2020 Wastewater Convention?

As an attendee you'll be able to earn CEUs, meet with the people who service Minnesota's onsite industry, and network with other industry professionals. MOWA's mission is promoting professionalism in the wastewater industry. This is achieved through involvement in education, legislation and government relations activities, and by hosting the only onsite wastewater convention in the state. MOWA is recognized as an important source of guidance to local and state agencies in policy and rule development. The organization works closely with the U



of M's Onsite Sewage Treatment Program and the Minnesota Pollution Control Agency to enhance education, policies, and research benefiting professionals, homeowners, government officials, and community leaders.

Why Visit Mankato?

Escape from the everyday in Mankato. While you're here, you'll also find just the right combination of small town feel and a thriving regional center. Mankato is a hub for arts, entertainment, shopping, and nightlife and it's all so close. Just a short 75 minutes from Minneapolis, Mankato is an easily accessible Minnesota destination of choice.

Lodging

Discounted nightly room rates for convention attendees are available at the Hilton Garden Inn

conveniently located next door to the Civic Center. See the Schedule on Page 6 for Hilton Garden Inn rates and details.

We look forward to seeing you in Mankato January 28th & 29th, 2020! ■

Mike Capra
MOWA President

Sara Heger & Travis Johnson
2020 Convention/Education Committee Co-Chairs

2020 Convention Committee

- | | | |
|-----------------|----------------|---------------|
| Mike Capra | Chris LeClair | Ben Rynda |
| Stacey Feser | Bernie Miller | Matt Summers |
| Dean Flygare | Pete Otterness | Cindy Tiemann |
| Jessica Fosberg | Alex Pepin | Andy Winkler |
| Nick Haig | | |



Don't Skip this Convention! Highlights and Events!

You won't want to miss....

The MOWA membership spoke and the Convention Committee heard a clear request for a two-day conference loaded with timely keynotes, technical information, and opportunities to met with suppliers and manufacturers... all while maintaining a network of colleagues and friends within the onsite industry! Here's a rundown of highlights and events! ■



KEYNOTE!

Septic System Impacts Due to Climate Change
 Kenny Blumenfeld,
 Sr. Climatologist, MN DNR

INFORMATION YOU CAN COUNT ON!

- 3** State and National Industry Updates
- 5** Open Forums for Designers, Service Providers, Inspectors & Maintainers
- 31** Relevant & Timely Presentations

Relax, Reconnect & Recharge!

- Silent Auction—
- MOWA Banquet—
- Awards & Live Auction—
- Casino Night—



KEYNOTE!

The Evolution of Onsite Wastewater Treatment
 Tom Fritts, VP, Residential Sewage Treatment Co.

Preview products and get questions answered at the Trade Show. Over 30 industry Suppliers or Manufacturers!!

CONVENTION-AT-A-GLANCE!

Tuesday, January 28th

Trade Show Set-Up	7:00 am – 11:00 am
Registration	7:30 am – 9:00 am
MOWA President's Welcome	8:00 am – 8:15 am
NOWRA Update	8:15 am – 8:30 am
MPCA Update	8:30 am – 9:20 am
Keynote Speaker: <i>Kenny Blumenfeld</i>	9:20 am – 10:10 am
Keynote Speaker: <i>Tom Fritts</i>	10:10 am – 11:00 am
Trade Show Opens – Silent Auction	11:00 am – 1:20 pm
MPCA Retest*	1:00 pm – 5:00 pm
Concurrent Sessions	1:20 pm – 3:00 pm
Vendor Show –	
Appetizers, Games & Prizes!	3:00 pm – 6:00 pm
Banquet – Awards and Live Auction	6:00 pm – 8:00 pm
Casino Night	8:00 pm – 10:00 pm

Wednesday, January 29th

Registration	7:30 am – 9:00 am
Concurrent Sessions	8:00 am – 12:30 pm
Tank Manufacturers Meeting**	10:00 am – 10:50 am
Lunch – Membership Meeting	12:30 pm – 1:30 pm
Concurrent Sessions	1:30 pm – 4:10 pm
MOWA Board Meeting	4:15 pm – 5:30 pm

*MPCA Retest available at no fee

** Tank Manufacturers Meeting Attendees must register for at least one day of the convention to attend



500 S. Front St., downtown Mankato



For more information

go to www.mowa-mn.com

Or check us out on Facebook and Twitter



[fb.me/MNOntsite](https://www.facebook.com/MNOntsite)
<https://twitter.com/MNOntsite>



2020 ANNUAL CONVENTION

EVOLUTION OF ONSITE WASTEWATER TREATMENT

Mankato Civic Center - January 28 and 29, 2020

January 27th - Conference Kick-Off at Pub 500, 500 S. Front St., from 6-9 PM

Tuesday, January 28, 2020

Start	Finish	Schedule, General Session Room: Banquet Hall			
7:30 AM	9:00 AM	Registration Opens, Front Street Lobby (area outside of Banquet Hall)			
7:30 AM	9:00 AM	Continental Breakfast			
8:00 AM	8:15 AM	MOWA Update, Mike Capra			
8:15 AM	8:30 AM	NOWRA Update, Sara Heger			
8:30 AM	9:20 AM	General MPCA Update, Aaron Jensen			
9:20 AM	10:10 AM	Septic System Impacts Due to Climate Change, Kenny Blumenfeld			
10:10 AM	11:00 AM	The Evolution of Onsite Wastewater Treatment, Tom Fritts			
11:00 AM	1:20 PM	Trade Show with Lunch Provided and Silent Auction in Grand Hall			
Tracks		I - Type IV and Tanks	II - Policy	III - Forum Track	IV - Freezing Issues
Room		Room 243	Room 247	Room 245	Room 241
Start	Finish	MPCA Exam Re-Testing Opportunity, Room 279B			
1:00 PM	5:00 PM	MPCA Exam Re-Testing Opportunity, Room 279B			
1:20 PM	2:10 PM	Hand-on in the Exhibit Hall Watertight Tanks - Focus on Risers, Claude Goguen, Chris Rienardy & Dean Flygare	MPCA Rule and Policy Update, Brandon Montgomery	Installer Open Forum: Jake Bell, Mike Capra	Freezing Case Studies and Solutions, Rick Smith and Bernie Miller
2:10 PM	3:00 PM	Membrane BioReactor Application in Minnesota, Tony Birrittieri	LGU Open Forum: Pat Schultz, Jessica Fosberg		Panel: Freezing Septic System, Dean Flygare and Rick Smith
3:00 PM	6:00 PM	Vendor Show with Silent Auction in Grand Hall			
6:00 PM	10:00 PM	Conference Banquet, Awards, Live Auction and Casino Night, Banquet Hall			

LODGING



20 Civic Center Plaza / Mankato, MN 56001

www.mankatodowntown.hgi.com

Discounted MOWA Rate: King or Queen Standard Room: \$119.00 - **Reserve By January 6, 2020**

Call 507.344.1111 and reserve under "2020 MN Onsite Wastewater Association" block

Wednesday, January 29, 2020

Start	Finish				
7:30 AM	9:30 AM	Continental Breakfast, Banquet Hall			
Session Tracks		I- Type III & Type IV Systems	II - Design and Installation	III - Forum Track	IV - Business and Safety Track
Room		Room 243	Room 247	Room 245	Room 241
Start	Finish				
8:00 AM	8:50 AM	Chlorine for Disinfection, Scott Hetrick	Redox Development, Brandon Montgomery	Design Open Forum: Wayne Johnson, Brian Brogard, Tom Wirtzfeld	Importance of Locating Utilities and Damage Prevention, Justin Larson
8:50 AM	9:40 AM	All Of The Good Lots Are Gone: Type III Design Problems and Solutions, Tim Haeg	Mitigation of MIC Through the Management of Hydrogen Sulfide Gas, Claude Goguen		Asset Protection, Tax Reduction, and Estate Planning, Larry Oxenham
9:40 AM	10:00 AM	Break			
10:00 AM	10:50 AM	Design Considerations for High Strength Wastewater Treatment, Allison Blodig	System Failure Identification, Jim King	Service Provider Open: Wayne Johnson, Tom Wirtzfeld	Succession Strategies to Protect and Perpetuate your Business, Larry Oxenham
10:00 AM	10:50 AM	Tank Manufacturer's Meeting, Room 279 B			
10:50 AM	11:40 AM	Failing Mound: Remediate, Rebuild or Replace, Bernie Miller	Onsite System for Medical Clinic and Bath House in Haiti, Alex Pepin	Inspector Open Forum: Brian Humpal, Bill Schueller	Starting or Running an Onsite Business - What is your Niche?, Tom Fritts
11:40 AM	12:30 PM	Installation Considerations when Rebuilding with Case Studies, Brian Koski	Providing Wastewater Treatment to the North Dakota Oil Fields, Allison Blodig		Common Law Employment Mistakes You Can Fix TODAY!, Cory Genelin
12:30 PM	1:30 PM	Lunch Provided with Membership Meeting, Reception Hall			
1:30 PM	2:20 PM	Type III Installation Case Studies, Dean Flygare and Bernie Miller	Design of Eljen in Mound Systems, Eric Daniels	Maintainer Open Forum: Cindy Tiemann, Lee Weigt	Health Insurance for Today - Options, Joni Tulenchik
2:20 PM	3:10 PM	Type III Permitting, Lori Brinkman, Marilee DeGroot, Peter Otterness	Eljen - Installation and Service, Eric Daniels		Getting Paid: Liens and Other Collection Options, Cory Genelin
3:10 PM	3:20 PM	Break			
3:20 PM	4:10 PM	Panel: Permitting across LGU lines for Type IV systems and MSTs: Wendy Cherpich, Peter Otterness, Tim Haeg, Mary VonEschen	Concerns with Lint/Microplastics in Wastewater and Septic Systems, Sara Heger	MOWA Summer Seminar 2020 at Camp Omega, Waterville, MN, Greg Halling	What You Don't Know Can Hurt You: Are You Prepared For What's Lurking In That SSTS?, Cindy Tiemann
4:15 PM	5:30 PM	Board of Directors Meeting, Room 279B			



MOWA Depends on Member Support!

Buy a Convention Sponsorship!

Or Contribute Items to the Silent & Live Auction!

This year, attendees can become Scholarship Sponsors!

Working together, we can continue to grow our industry by providing educational opportunities. Just fill out the form below and return it with your Attendee or Exhibitor Registration.

Contributing items for the Silent or Live Auction is another way you can help our industry. Proceeds for the auction are used to provide scholarships from MOWA through the Tony Ruppert Scholarship Fund. ■



Kudos to MOWA Boosters, Teri James, Cindy Tiemann, and LeeAnn Weigt, shown above at the 2018 Convention promoting the Auctions and Raffle.

MOWA Attendee Sponsorship Opportunities

To contribute a sponsorship, please fill out this form and return it to MOWA by January 10, 2020

- \$25 – Bronze Sponsor:** Acknowledgement on Conference Signage
- \$50 – Silver Sponsor:** Acknowledgement on Conference Signage and in Conference Packet
- \$100 – Gold Sponsor:** Acknowledgement on Conference Signage and in Conference Packet, on MOWA Website and Facebook Page
- \$250 – Platinum Sponsor:** Acknowledgement on Conference Signage and in Conference Packet, on MOWA Website and Facebook Page, plus link to your business website

Payment:

Check: Payable to MOWAAmount: \$ _____

Mail to: MOWA, 5021 Vernon Ave., So., #241, Edina, MN 55436

Credit Card: Fax to - (952) 487-4447, Mail to - address above, or Email to – mowacarla@aol.com

Type of Card: Visa MasterCardAmount: \$ _____

Credit Card # _____ Expire Date: _____ / _____ CVV Code: _____

Cardholder: _____ Signature: _____

By this signature, I authorize MOWA to process fees pertaining to this MN Onsite Wastewater Convention.

Precast Systems Concrete Products

Serving the area for over 40 years!

116 E. Hwy. 12 • Darwin, MN 55324

Toll Free 888-693-8440

320-693-8440 • Fax: 320-693-9593

www.darwinconcrete.com

Septic Tanks
Holding Tanks
Traffic Load Rated
Grease Interceptors

Septic tanks are designed to exceed industry standards.

Guaranteed water tight.
Vacuum testing available.
Prompt Delivery.

OVERLAND INSURANCE AGENCY



Our office has been the Administrating Agency for over 20 years. We know the Wastewater Industry.

Mike Overland

Nate Overland

Harold Overland

Call us for your Bonding or Insurance questions.

Phone: (888) 346-6250

Fax: (218) 346-9261

Website: <http://www.overlandinsurance.com>

255 3rd Ave SE

P.O. Box 150

Perham, MN 56573



Register Now—Early Bird Discount Available!

MOWA 2020 CONVENTION January 28-29, 2020: Mankato Civic Center

ATTENDEE REGISTRATION Early Bird Deadline: January 10th, 2020

(One form per person, please make copies for additional individuals)

Company Name: _____ Contact: _____

Address: _____

City, State, Zip: _____

Phone: _____ Fax: _____ E-Mail: _____

MOWA MEMBERS

By January 20th, 2020:

- Both Days - 1st Company Rep.\$295
- Both Days - Subsequent Rep.\$245
- 1 Day: Tues. OR Weds., 1st Company Rep.\$195
- 1 Day: Tues. OR Weds.- Subsequent Rep.\$170

After January 20th, 2020: WALK-IN

- Both Days - 1st Company Rep.\$395
- Both Days - Subsequent Rep.\$345
- 1 Day: Tues. OR Weds., 1st Company Rep.\$295
- 1 Day: Tues. OR Weds.- Subsequent Rep.\$270

For our Business/Government members, 1st attendee registers at the "1st" Company Rep." rate; all other attendees who are members of the same organization receive the "Subsequent Rep." rate.

NON-MEMBERS*

By January 10th, 2020:

- Both Days\$375
- 1 Day: Tues. OR Weds.\$275

After January 10th, 2020: WALK-IN

- Both Days\$475
- 1 Day: Tues. OR Weds.\$325

STUDENTS

- Student\$95

*Join or renew your membership today and receive special member conference rates (see back page for application)

Total Attendee Registration

General Registration =\$ _____

_____ Number attending Banquet _____ Number attending Casino Night _____ Sponsorship Form attached

Please circle the day(s) you will attend: Tuesday - Wednesday

Additional Lunch and/or Trade Show and/or Banquet Tickets (1 ticket for each event)

Lunch Name: _____ Name: _____ # _____ X \$35.00 = \$ _____

Trade Show Name: _____ Name: _____ # _____ X \$35.00 = \$ _____

Banquet Name: _____ Name: _____ # _____ X \$35.00 = \$ _____

Grand Total =\$ _____

Payment

Check: Payable to MOWAAmount: \$ _____

Mail to: MOWA, 5021 Vernon Ave., So., #241, Edina, MN 55436

Credit Card: Fax to - (952) 487-4447, Mail to - address above, or Email to - mowacarla@aol.com

Type of Card: Visa MasterCard Amount: \$ _____

Credit Card # _____ Expire Date: _____ / _____ CVV Code: _____

Cardholder: _____ Signature: _____

By this signature, I authorize MOWA to process fees pertaining to this MN Onsite Wastewater Convention.

I agree to indemnify and hold harmless Minnesota Onsite Wastewater Association (MOWA), from any and all liability, loss, damage, or expense from any incident which may arise while attending any portion of the 2020 MOWA Annual Convention. If applies, I authorize any photos taken of me at this event to be published in MOWA's Little Digger and/or other MOWA-related promotional materials.

Signature: _____ Date: _____



Exhibitor Registration—Deadline January 3, 2020!

MOWA 2020 CONVENTION January 28-29, 2020: Mankato Civic Center EXHIBITOR REGISTRATION Deadline: January 3rd, 2020

Company Name: _____ (As it should appear on exhibitor sign)
 Contact Name: _____ Contact Email: _____
 Preferred Mailing Address: _____
 City: _____ State/Province: _____ Zip/Postal Code: _____
 Country: _____ Telephone: (____) _____ Fax: (____) _____

Vendor Representatives (2 representatives are include with each booth rental)

1st Booth: Name 1. _____ Name 2. _____
 Circle days attending: Tuesday Wednesday Tuesday Wednesday
 2nd Booth: Name 1. _____ Name 2. _____
 Circle days attending: Tuesday Wednesday Tuesday Wednesday
 _____ Number attending Banquet _____ Number attending Casino Night _____ Sponsorship Form attached
BOOTH PREFERENCE: (See map Page 12) First Choice # _____ 2nd Choice # _____ 3rd Choice# _____ prefer not near _____

Exhibitor Convention Fees

- Booth Registration Fees:**
 PLEASE CHECK APPROPRIATE REGISTRATION FEES
 MOWA Member - First Booth space \$600
 Non-MOWA Member* – First Booth Space \$940
 Additional Booth Spaces \$280 each X _____
*Send in your MOWA Membership Application today and register at the member rate!
Booth Registration Fees \$ _____
- Outreach and Scholarship Fund Fees:** (see Page 13)
 Bronze Sponsor \$100
 Silver Sponsor \$250
 Gold Sponsor \$500
 Platinum Sponsor \$750
Outreach & Scholarship Fund Fees \$ _____
- Event Sponsorship:** (see Page 13)
 Breaks – both days \$250
 Continental Breakfast – both days \$250
 Tuesday Afternoon Reception \$250
 Tuesday Evening Banquet \$250
 Tuesday Evening Casino Night \$250
Event Sponsorship \$ _____
- Auction item Donation or Cash Donation:** (Required for all non-Scholarship sponsors)
 \$50 (Not required for Scholarship Sponsors!)
 If you are bringing an auction item in lieu of \$50.00 please list item(s): _____
Auction/Scholarship Donation \$ _____

TOTAL PAYMENT DUE \$ _____
MUST BE RECEIVED BY JANUARY 3, 2020

Payment

Check: Payable to MOWA Amount: \$ _____
Mail to: MOWA, 5021 Vernon Ave., So., #241, Edina, MN 55436
 Credit Card: Fax to - (952) 487-4447, Mail to - address above, or Email to – mowacarla@aol.com
 Type of Card: Visa MasterCard Amount: \$ _____
 Credit Card # _____ Expire Date: _____ / _____ CVV Code: _____
 Cardholder: _____ Signature: _____
By this signature, I authorize MOWA to process fees pertaining to this MN Onsite Wastewater Convention.

I agree to indemnify and hold harmless Minnesota Onsite Wastewater Association (MOWA), from any and all liability, loss, damage, or expense from any incident which may arise while attending any portion of the 2020 MOWA Annual Convention. If applies, I authorize any photos taken of me at this event to be published in MOWA's Little Digger and/or other MOWA-related promotional materials.
 Signature: _____ Date: _____



A Message for Convention Exhibitors!

Dear Exhibitor:

The Minnesota Onsite Wastewater Association, in cooperation with the University of Minnesota and the Minnesota Pollution Control Agency, will present the 2020 Minnesota Onsite Wastewater Convention January 28th and 29th, 2020! The Trade Show is a very important part of our convention. **MOWA offers exhibitors the opportunity to contact industry professionals AND show support for MOWA at the only onsite convention in Minnesota.**

At the 2020 convention, we will offer over 30 booths to exhibitors at the state-of-the-art Mankato Civic Center.

This year, we are pleased to continue the two-day convention format and sponsorship opportunities introduced in 2017. Exhibitors will have the choice to attend both days of the convention—including all CEUs, meals and entertainment—for the single price of the booth fee!

We will also be holding a social event at Pub 500 in downtown Mankato on Monday evening, and are excited to feature a Casino Event following the Tuesday night banquet. We are bringing back sponsorship—with some new opportunities available this year—as well as games and prizes geared toward exhibitor-attendee interaction.



**EXHIBITOR REGISTRATION DUE
JANUARY 3, 2020!**

Why join us at the 2020 Wastewater Convention?

As an exhibitor you'll be able to meet with the people that service Minnesota's onsite industry, show your products, answer their questions and make the contacts you want for future sales!

MOWA's mission is promoting professionalism in the onsite wastewater industry. This is achieved through involvement in education, legislation and government relations activities, and by hosting the only onsite wastewater convention in the state. MOWA is recognized as an important source of guidance to local and state agencies in policy and rule development. MOWA works closely with the U of M's Onsite Sewage Treatment Program and the Minnesota Pollution Control Agency to enhance education, develop and improve policies, and promote research. All of which benefit wastewater professionals, homeowners, government officials, and community leaders alike.

None of these accomplishments happen without the support and leadership of MOWA members and industry suppliers and manufacturers. "Come grow with us" by exhibiting at our annual convention and talk to the leaders in Minnesota's onsite wastewater industry. ■



Join your Friends & Colleagues at the Annual MOWA Convention Banquet, Auction and Casino Night!

MOWA staff and Board members know that you work hard year-round, so this is your night to kick-back, swap stories and generally have a good time!

Auction Items of Note this year include:

- Guided Fishing Trip on Mille Lacs**
- Minnesota Wild tickets**
- Twins Season Opener Tickets**

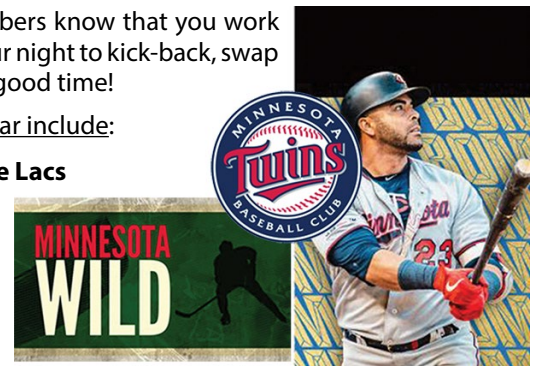



Trade Show's 30 booths of exhibitors cover it all!



MOWA TRADE SHOW

Tuesday, January 28

GRAND HALL

30 booths - Seating Capacity 240

MANKATO CIVIC CENTER

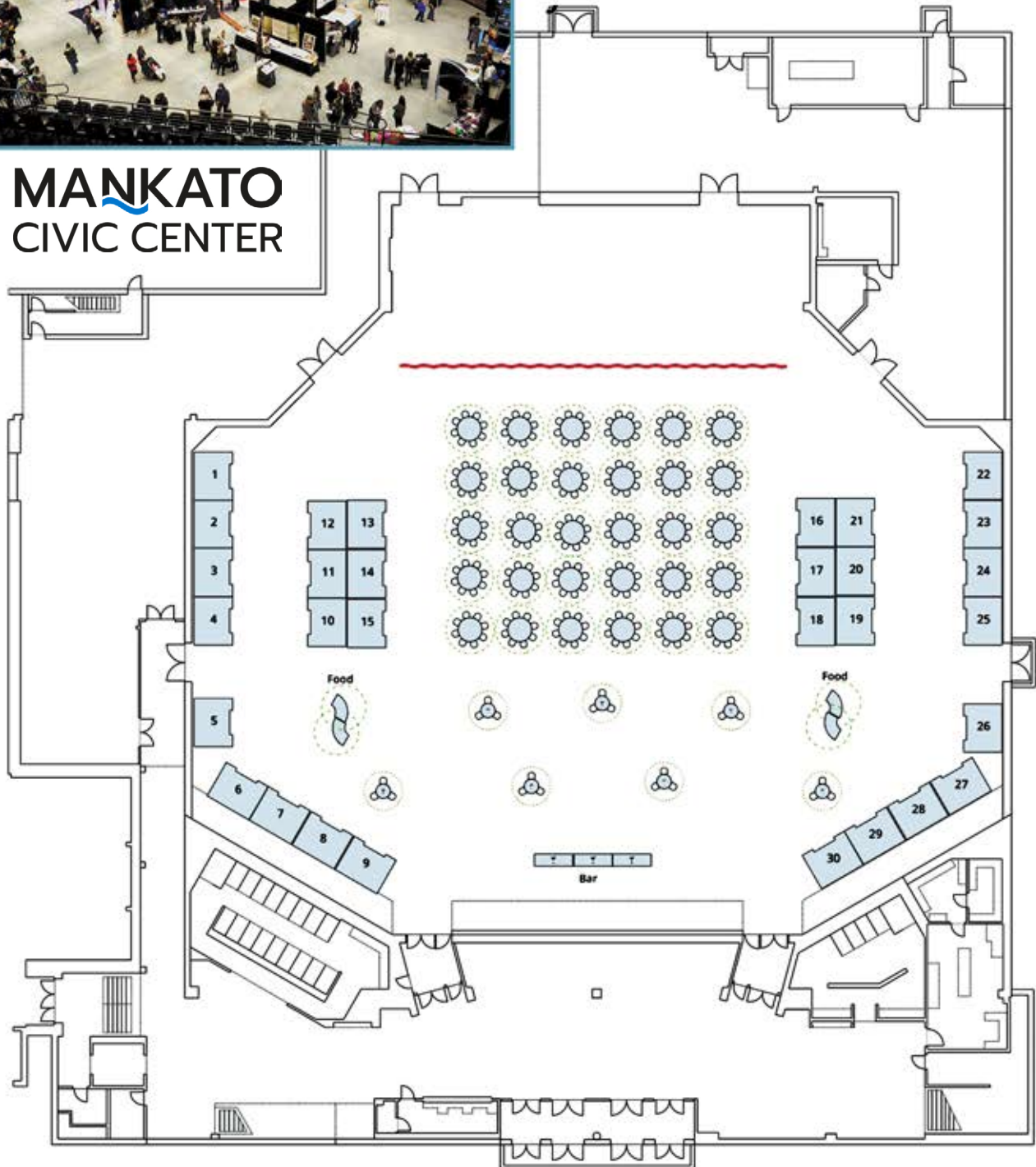



Vendor Information and Opportunities!

Exhibitors' One-Stop for 2020 Convention Fees and other information!

Exhibitor Fees

- MOWA Members 1st booth** - \$600 + Youth Scholarship sponsorship or minimum \$50 Auction Item
- Non-MOWA Members 1st booth** - \$940 + Youth Scholarship sponsorship or minimum \$50 Auction item (submit MOWA Membership Application with this registration to receive Member rate of \$600)
- Additional booths** - \$280 each + \$50 auction item (*auction item requirement waived for scholarship sponsors*)
- Refund Policy** - Written notice of cancellation must be received prior to January 15, 2020. 50% refund will be given, less \$25 processing fee.
- Scholarship Auction Item** - All exhibitors are required as part of their booth fee to provide 1 or more "industry related items" of at least \$50 in value to be auctioned off during the Silent Auction commencing at 11:00 am on Tuesday, January 28th to benefit the MOWA Outreach and Scholarship Fund. Exhibitors may elect to pay an additional \$50 Registration Fee per booth in lieu of contributing an Auction Item. The Convention Committee will then purchase an auction item on your behalf. Please see additional details on exhibitor application page. (*Auction item/\$50 requirement waived for Outreach and Scholarship Fund Sponsors*)

Booth registration includes:

- 8' (deep) x 10' (wide) space
- Piping and drapes
- 4" x 42" sign with company name
- 8' x 30" skirted display table and 2 chairs

Details

- Each booth space includes (2) two-day convention registrations
- Additional vendor representative registrations are available for \$100 each – trade show attendance only.
- To participate in the rest of the convention, additional vendor representatives must register separately as convention attendees via the convention brochure. Contact MOWA for materials.
- Electrical Power –provided through Mankato Civic Center (see Pages 17-18)

Outreach and Scholarship Fund Sponsorship

Historically MOWA has accepted auction items as vendor donations that support our scholarship efforts. However, several members and vendors have requested more opportunities to support this effort. We hope that the following sponsorship options are appealing to many of you! As an incentive, we are providing our sponsors with several great advertising opportunities at each sponsorship level!

- \$100 – Bronze Sponsor:** recognized on Conference Signage
- \$250 – Silver Sponsor:** recognized on Conference Signage and in Conference Packet
- \$500 – Gold Sponsor:** recognized on Conference Signage and in Conference Packet, on MOWA Website and Facebook Page
- \$750 – Platinum Sponsor:** recognized on Conference Signage and in Conference Packet, on MOWA Website and Facebook Page, plus link to your business website

***In lieu of cash sponsorship donations, Vendors may opt to donate a Silent Auction item of equal or greater value as their sponsorship at their desired level.**

Event Sponsorship

Event sponsorship is an optional convention fee, and sponsors will be recognized in the Onsite Brochure, Program, Table Signs and on Easels.

- \$250 - Breaks** – both days
- \$250 - Continental Breakfast** – both days
- \$250 - Tuesday Afternoon Reception**
- \$500 - Tuesday Evening Banquet**
- \$250 - Tuesday Evening Casino Night**
- \$250 - Casino Night Table Signage** with your logo displayed

EXPERIENCE THAT MATTERS QUALITY THAT LASTS!

- ◆ **Septic, Grease Interceptors, Aeration, Holding Tanks**
- ◆ **Available in Sizes 750 to 40,000 Gallon**
- ◆ **Extra Heavy Duty Tanks – HS20 Loading**
- ◆ **Bituminous Coating, Fast, Efficient Setting**
- ◆ **Vacuum-Tested, Water Tight Structures**
- ◆ **Tanks for Bio-Microbics and Nibblers, Sand Filters**
- ◆ **Custom Sizes Available to Fit Your Needs**



WIESER Innovation, Quality
and Service
Since 1963
CONCRETE

1-800-325-8456

wieserconcrete.com



For Exhibitors—Trade Show Rules & Booths

Booth Display Rules

Trade Show Set-up /Tear-down Schedule:

- Booth set-up:** Tuesday, January 28th 7 am – 11 am
- Tear-down:** Tuesday, January 28th 7 pm – 9 pm

Booth Display Time

- Trade Show:** Opens Tuesday, January 28th 11am – 1:15 pm
- Trade Show:** Tuesday, January 29th 3 pm - 6 pm

Space

- No portion of the booth area may be sublet or assigned to any other firm or person(s).

Space Assignments

- Booth and/or rig space assignments are made on a first come, first serve basis. Indicate your first, second, and third choice for booth and/or space.
- The Exhibitor application form offers you the opportunity to indicate competitors you would prefer to not be placed next to. No private room displays. Hosting Associations reserve the right to alter Trade Show layout and vendor location.

Fire/Safety Codes

- Each booth operator must comply with all federal, state, local and Resort fire and safety codes.

Insurance

- It is agreed that in no case shall MOWA, University of Minnesota, MPCA or their officers or directors be responsible for any loss, theft, damage by fire, or injury to any person or article.

Liability

- Each booth operator will be responsible for the space leased during the convention and will keep it free from hazards to persons on the premises. MOWA, University of Minnesota, or MPCA will not be responsible for any injury that may occur to booth operators, their associates or employees.





MOWA Scholarship Auction

- All exhibitors are required, as part of their booth fee, to either become a scholarship sponsor or provide an “industry related items” of at least \$50 in value to be auctioned off at the conventions silent auction.
- All auction items will be collected by MOWA and displayed in a central location in the Exhibit Hall. The exhibitor providing the item will be named on each item. Examples of items for the auction – pumps, safety equipment, filters, control panels. No vendor advertising items, please.
- Exhibitors may elect to pay a \$50 Registration Fee in lieu of the Auction Item. The Convention Committee will then purchase an auction item on your behalf. Fee must be paid at time of booth registration. ■

THE IMPERIAL BASELINE SERIES

WHY IMPERIAL?

- Best service after the sale
- Top quality
- You're not a customer, you're a partner, because our name is on the truck too
- Over 150,000 tanks built
- 22 engineers and designers on staff for all your tank needs

2020 INTERNATIONAL MV 607	2500-GALLON ALUMINUM TANK	2020 INTERNATIONAL HV 607	4000-GALLON ALUMINUM TANK
	CUMMINS ENGINE NVE 607 FAN-COOLED 380 CFM PUMP <i>Also available with 2019 Freightliner M2-106 body: \$110,900</i>		350HP CUMMINS ENGINE NVE 607 FAN-COOLED 380 CFM PUMP <i>Also available with 2019 Freightliner M2-106 body: \$128,641</i>
	\$100,766 lease for as low as \$1,199 OAC/mo		\$124,878 lease for as low as \$1,778 OAC/mo
2019 FORD F550 V-10 4X2	980-GALLON STEEL TANK	2018 RAM 5500 HEMI 4X2	1300-GALLON ALUMINUM TANK
	GAS ENGINE, MASPORT HXL4 160 CFM PUMP <i>Also available with diesel engine: \$73,791 Also available on a Ram</i>		GAS ENGINE, MASPORT HXL4 160 CFM PUMP <i>Also available with diesel engine: \$82,998 Also available on a Ford</i>
	\$65,328 \$972.93 OAC/mo		\$75,545 \$1,125.09 OAC/mo

ORDER YOURS TODAY BY CALLING
1-800-558-2945 OR VISITING IMPERIALIND.COM.



IMPERIAL
INDUSTRIES INC.

Imperial Industries, proudly family-owned and operated in central Wisconsin for more than 35 years, is the trusted choice for specialized septic solutions and expert service.



THE PERFECT FIT EVERY TIME!

We heard you! Polylok now offers risers in 2" and 3" heights. Whether you are working with a septic tank, distribution box or drainage box, stacking these new heights with our existing series of 6" and 12" risers will enable you to get **the perfect fit every time!**

Worried about safety? We are too! That's why you can install a concrete plug in our 20" and 24" riser pans. Additionally, we offer 12", 20" and 24" riser safety screens that provide a secondary layer of protection.

RISER SAFETY ACCESSORIES



Safety Screens
 (12") 3017-SS
 (20") 3009-SS
 (24") 3008-SS

Lid-Lok Safety Device
 (20") 3009-LOK
 (24") 3008-LOK



24" Dual Safety Cover
 3009-KYDC



24" x 2" Riser
 3008-GR2



20" x 2" Riser
 3009-GR2



20" x 3" Riser / Riser Pan
 3009-LPRP

OTHER SIZES AVAILABLE

- 24" x 3" Riser / Riser Pan - 3008-RP
- 24" x 6" Riser - 3008
- 24" x 12" Riser - 3008-R12
- 20" x 6" Riser - 3009
- 20" x 12" Riser - 3009-R12
- 20" Riser Pan - 3009-RP
- 12" x 6" Riser - 3017-R



1-877-765-9565 / www.polylok.com
 For more information call or visit our website today!

Owner wishes to retire!!!

Septic and drain business for sale in south central Minnesota established in 1951.

I have a great business for sale. My dad started the business in 1951 and we have been going strong ever since. We've had a great reputation in this area for over 60 years. We do septic pumping, drain cleaning, jetting, camera, locating and pump replacement. We service every part of septic systems. Equipment includes: 2 septic trucks: 2007 and 2003 Kenworths, 10 speeds with cummins engines. Both trucks have 3500 gallon stainless steel tanks with hoists, 1000 CFM blowers, 3000 gallon waste, and 500 gallon fresh water compartments. They have 2" pressure pumps for easy cleaning of septic tanks, pits etc. I bought these trucks new, the stainless tanks will never have to be replaced.



2002 Ford transit style bus

This unit is a rolling shop. Equipped with 2 jetters, a 300 gallon water tank, many roto rooting machines plus sewer camera and locators. Everything to do the job. 1 steam trailer for thawing frozen pipes, equipment cleaning, etc., 300 gallon water tank, self contained unit. 40,000 gallon temporary storage tanks and 14 acres PCA approved spread site, which I rent from a local farmer. 300 plus customers on my pump list which I started 25 years ago. Also for rent a 3-stall heated shop with wash bay, mechanic pit and tools plus new 40x80 building.

A great turn key business with 60 plus years in the area. Please look at my website to view pictures of some of the equipment. I bought the 03 Kenworth new for \$130,000 and the 07 Kenworth new for \$190,000. The 03 has 230,000 miles and the 07 Kenworth has 130,000. The gross income for 2017 was \$520,776.24

T.A. Lauritsen Septic & Drain Inc. • 4455 Hwy 212 • Montevideo MN 56265 • 320-269-2920

WILLMAR PRECAST COMPANY

Products, Services & Solutions for Your Septic Installation

"Helping put money in your pocket and not down the drain."

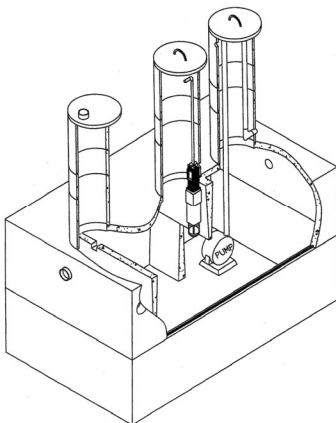

Concrete Drop Boxes

Straight 1000-3500 Gallon Septic Tanks
1500-3500 Gallon Combination Lift Tank & Septic Tank
Complete line of Zoeller pumps, gravelless drain field and filter fabric

- Complete line of tanks to accept effluent filters
- Prompt delivery on your schedule
- Entry to the tank can be made from either side or the end
- Tanks designed to conform to standards set by the Minnesota Pollution Control Agency
- Engineer designs available upon request

For ordering, pricing and other information, please contact:

Willmar Precast Company
Toll Free: 1-800-559-8527



For Exhibitors—Mankato Civic Center Order Form

MN Onsite Wastewater Association Convention
January 28, 2020

MANKATO
CIVIC CENTER

Items checked below are in addition to the furniture listed above and are at the expense of the exhibitor at the rates listed below.
ALL PRICES ARE PER SHOW COST plus APPLICABLE SALES TAX. Mankato Civic Center.
 equipment and services are being furnished subject to regulations. Orders will be completed only after payment in full is received.

A. Shipments

Shipping **to** Mankato Civic Center – Items shipped more than 5 Days in advance of conference are subject to \$100/day fee.

Shipping **from** Mankato Civic Center – Pre-Purchase and Attach Shipping Label, Call to Schedule Pick-Up

	Advance	Day Of	Totals
B. Equipment (*Note-Booths come with 1-6' table and 2 Chairs at no cost, items below are in addition.)			
___ Carpet	\$200	N/A	_____
___ 6' Table – Skirted	\$15	\$30	_____
___ 8' Table – Skirted	\$15	\$30	_____
___ Cabaret Table – Skirted	\$20	\$40	_____
___ Banquet Chair	\$10	\$20	_____
___ Black Leather Stool	\$15	\$30	_____
___ Easels	\$15	\$30	_____
___ Flip Boards	\$20	\$40	_____
___ Dry Erase Board w/ Markers	\$20	\$40	_____
C. Electrical			
___ 120 V. 20 amp <i>single outlet</i>	\$30	\$60	_____
___ 220 V. 30 amp single phase*	\$75	\$150	_____
___ 220 V. 30 amp three phase*	\$150	\$300	_____
___ Hardwired Internet (WiFi – Free)	\$75	\$150	_____
D. Forklift (per use)	\$100	\$200	_____
		SUBTOTAL	_____
		TAX TBA	_____
		GRAND TOTAL	_____

***Note:** Any power 30 amp single phase and up is subject to a separate electrical bill along with an inspection fee. The total bill may have to be determined on the day of the show. If at all possible, please include a picture of the cable ends or plugs you plan to use so that we are prepared for your arrival, as electrical requirements vary at each expo or show.

***Notice:** Payment in full must accompany any order. Floor rates will apply to all orders not received 7 days prior to move in of show. Orders placed at service desk must be paid at time of order. **Make checks payable to Mankato Civic Center.** NOTE: There will be a \$30.00 charge for all checks returned due to non-sufficient funds.

Company Name _____ Contact Person _____ Booth Number _____

Address _____ City, State, Zip _____

Phone # () _____ E-Mail _____

Signature _____ Date _____

Return Order to: Claudia Hicks, Mankato Civic Center, One Civic Center Plaza, Mankato, MN 56001
 Call for Credit Card Orders - Phone (507) 387-8467

Original to Acct
 Copy to Tech
 Copy to Event Folder



For Exhibitors—Mankato Civic Center Order Form

IMPORTANT CONDITIONS AND REGULATIONS

1. Advance orders (paid in full) must be received a minimum of seven (7) days prior to scheduled exhibitor arrival for move-in.
2. Payment in Full must be rendered prior to start of show. Please DO NOT send cash in the mail.
3. All material and equipment furnished by the MANKATO CIVIC CENTER for this service order shall remain in the MANKATO CIVIC CENTER and shall be removed ONLY by the MANKATO CIVIC CENTER personnel at the close of the show.
4. Rates quoted for connections cover only the bringing of service to the booth in the most convenient manner and do not include connecting equipment to special wiring. Rates for special services such as placing cords or relocating services(s) will include a labor charge.
5. Wall, column and permanent building utility outlets are not a part of booth space and are not to be used by exhibitors.
6. All equipment, regardless of source of power, must comply with all federal, state and local safety codes.
7. Use of open clip sockets, latex or lamp cord wire, duplex or triplex attachment plugs in exhibits is prohibited.
8. Claims will not be considered unless filed by exhibitor to the MANKATO CIVIC CENTER PRIOR TO CLOSE OF SHOW.
9. Rates are based upon current rates and are subject to change without notice.
10. Under no circumstances shall anyone other than authorized MANKATO CIVIC CENTER personnel make electrical connections.
11. Special equipment requiring company engineers or technicians for assembly, service, preparatory work and operation may be executed without the MANKATO CIVIC CENTER electrician.
12. All equipment must be properly tagged and wired with complete information as to type of current, voltage, phase, cycle, horsepower, etc.
13. Electrical power for lights and displays will be turned on one hour prior to show opening time and off at show closing time daily.
14. Unless otherwise directed, MANKATO CIVIC CENTER electricians are authorized to cut floor coverings to permit installation of service.
15. All exhibitors' cords must be of 3-wire ground type. All exposed, non-current carrying metal parts of fixed equipment, which are liable to be energized, shall be grounded.
16. Requests for special voltage and/or other "Special requirements" (see Page 17) must be received by MANKATO CIVIC CENTER 30 days prior to scheduled exhibitor arrival and move-in.
17. Obstructions blocking utility floor boxes are subject to relocation as necessary.
18. BASIC BOOTH PACKAGE: 1 - 6' Table, 2 chairs and Pipe & Drape: 8' back, 3' wings (These items are provided by Lessee at the Lessee's expense and will be in your booth at the scheduled move-in date.)
19. The above-listed conditions and regulations are not all inclusive, additional rules will be given as applicable.

For MANKATO CIVIC CENTER use only

Completed by: _____

Amount Paid:

Date: _____

Date Paid:

Comments: _____

How Paid:

Received by:

For additional facilities information about Mankato Civic Center:

Contact Claudia Hicks, Event Sales & Services Coordinator at 507-387-8467 (chicks@mankatomn.gov)



2020 MEMBERSHIP APPLICATION

Membership: Renewal New Member

- Individual Member \$240 (1 person)
- Business Group /Government Unit \$340 (up to 5 people; \$100 /person after 5)
- Student \$140 (1 person)
- Life-time
- Honorary

Note: Your MOWA Membership includes one NOWRA membership

Memberships are based on calendar year - After July 1st, new members pay \$140-individual / \$190-business or gov't groups for remainder of 2020

Individual/Group Contact: This person will be listed as the NOWRA member on the Septic Locator website. They will be listed first in all MOWA publications. Please print clearly.

1st Member _____ Company Name _____
 Address _____ City/State/Zip _____
 Title _____ Phone _____ Mobile/800# _____ Fax _____
 Email _____ Website _____ County _____

Circle the counties you work in: Needed for Directory and website.

Statewide..... 88	Clay 14	Hubbard 29	Marshall 44	Pipestone 59	Steele 74
	Clearwater 15	Isanti 30	Martin 45	Polk 60	Stevens 75
Aitkin..... 1	Cook 16	Itasca 31	McLeod 46	Pope 61	Swift 76
Anoka 2	Cottonwood 17	Jackson 32	Meeker 47	Ramsey 62	Todd 77
Becker 3	Crow Wing 18	Kanabec 33	Mille Lacs 48	Red Lake 63	Traverse 78
Beltrami 4	Dakota 19	Kandiyohi 34	Morrison 49	Redwood 64	Wabasha 79
Benton 5	Dodge 20	Kittson 35	Mower 50	Renville 65	Wadena 80
Big Stone 6	Douglas 21	Koochiching 36	Murray 51	Rice 66	Waseca 81
Blue Earth 7	Faribault 22	Lac qui Parle Lake 37	Nicollet 52	Rock 67	Washington..... 82
Brown 8	Fillmore 23	Lake 38	Nobles 53	Roseau 68	Watonwan 83
Carlton 9	Freeborn 24	Lake of the Woods 39	Norman 54	Scott 69	Wilkin 84
Carver 10	Goodhue 25	Le Sueur 40	Olmsted 55	Sherburne 70	Winona 85
Cass 11	Grant 26	Lincoln 41	Otter Tail 56	Sibley 71	Wright 86
Chippewa 12	Hennepin 27	Lyon 42	Pennington 57	St. Louis 72	Yellow Medicine 87
Chisago 13	Houston 28	Mahnomen 43	Pine 58	Stearns 73	

Information: (Check all that apply)

- Installer Pumper Designer Inspector Gov't Regulator Educator Service Provider Student
- Soil Scientist Professional Engineer Manufacturer Operator/Maintenance Supplier Other: _____

Additional Business/Government Members:

2nd Member _____ Title _____ County _____
 Address _____ City/State/Zip _____
 Phone _____ Mobile/800# _____ Fax _____ Email _____

3rd Member _____ Title _____ County _____
 Address _____ City/State/Zip _____
 Phone _____ Mobile/800# _____ Fax _____ Email _____

(Please list additional business/government group members on separate sheet with complete contact information.)

Publications: Would you prefer receiving 'Little Digger' newsletters via ... Regular Mail Electronically
 We currently send one publication per address to business/government groups. Contact the MOWA office if you'd like additional copies.

Additional NOWRA Memberships: MOWA membership fees include one NOWRA membership per company/organization. List names of members who want additional NOWRA memberships here: Cost - \$40 per person.
 2) _____ 3) _____ 4) _____ 5) _____

Payment:
 (Please print) MOWA Membership \$ _____ + Add'l NOWRA Memberships = **Amount: \$** _____
 Check enclosed (Payable to MOWA) VISA MasterCard
 Card Number: _____ CVV: _____ Expiration Date: _____ Cardholder Name: _____
 Signature: _____ Date _____

MOWA, 5021 Vernon Ave, So., Suite 241, Edina, MN 55436 Phone: 612.801.5897 Fax: 952.487.4447

NOTE: Dues payable to MOWA are not deductible as a charitable contribution but may be deductible as an ordinary and necessary business expense. MOWA estimates that 10% of your MOWA dues are used for governmental affairs issues and therefore are not deductible.



Presorted
Standard
U.S. Postage
PAID
Rochester, MN
Permit No. 289

RETURN SERVICE REQUESTED

MOWA

5021 Vernon Ave, So., Suite 241
Edina, MN 55436
Phone: 612.801.5897
Fax: 952.487.4447

www.mowa-mn.com

EZconnex[®] 4-PORT SYSTEM

Revolutionary Float Switch Connection System

Installation is as easy as 1, 2, 3...Simply install the manifold, plug in the floats, and wire the manifold cable to the control panel. The color-coded cable makes for a quick, clean installation! The quick release float switch connections allow for easy maintenance and replacement of floats, saving installers time and money...up to 75%! Many float switch options and 3-port manifold available to suit your needs!



- Simple, clean installation
- Up to 4 quick release floats
- Mounts directly in riser
- Great for new and retrofit applications
- Easy maintenance



US Patent No.
9,559,455 and 9,583,867
Foreign Patents Pending

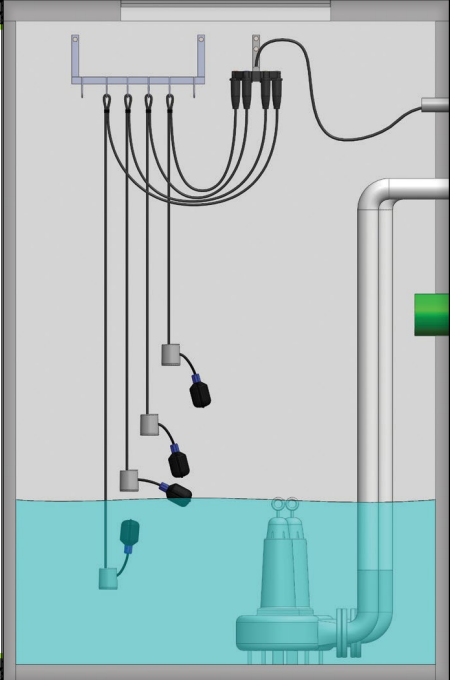

www.sjrhombus.com

